

showering packages

and electric showers
january 2017



12 year guarantee

VADO



contact us

sales 01934 744466 01934 744345 **fax**

email sales@vado.com www.vado.com **web**



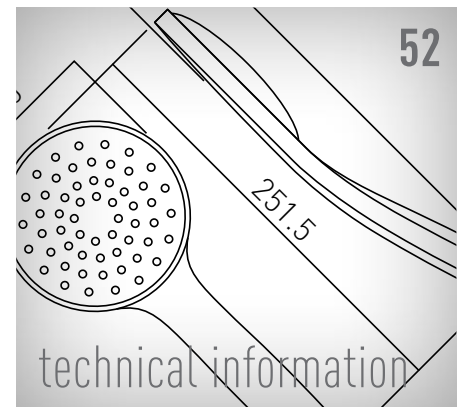

VADO is a leading British bathroom brassware manufacturer providing high quality taps, showers, accessories and fittings to customers across the globe.

every product that we offer is created and produced around our four core values

quality

All of our products are passed through stringent quality assurance processes to ensure that they reach the exacting standards that allow us to offer our 12 year guarantee.

design

Our products range from traditional mixers, shower valves and accessories to contemporary designs including waterfall style spouts, handle options in different colours and materials and products that use the latest digital control technology. Our global presence ensures we remain at the cutting edge of international design trends.

service

We pride ourselves on delivering outstanding customer service throughout the entire buying process, from initial query, through to delivery and aftersales care.

innovation

We have a team of people dedicated to developing product ranges that innovate in their form and function. We design products that not only look great but are easy to install, maintain and minimise environmental impact.



norcross

VADO is part of the Norcross Group

VADO's strict manufacturing processes ensure our products can be guaranteed for 12 years, giving peace of mind to all customers.

our exacting manufacturing standards are amongst the very best in the industry

at every stage of the production process there is a rigorous quality check



our products are quality checked a minimum of 8 times throughout the production process

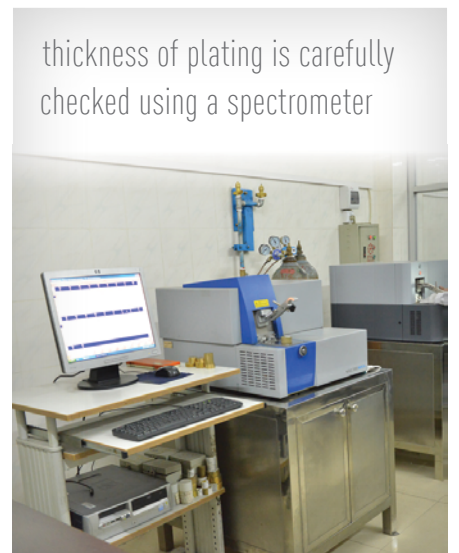

we work closely with the industry's leading standards organisations to reinforce our 12 year guarantee

it's a personal experience



VADO products can be found in some of the most prestigious hotel and residential developments throughout the world.



Millgate Homes, UK



The Shard, UK



London Hilton on Park Lane, UK



Countryside Properties, UK



Co-operative Group Headquarters, UK



Cornwall Hotel and Spa, UK



Angaga Island Resort, Maldives



The Chedi Hotel, Oman



Four Seasons Hotel, Hong Kong



Freemans Bay Offices, New Zealand



JW Marriott Marquis Hotel, Dubai



The Datai Langkawi Hotel, Malaysia

it's a personal experience



VADO has a passion for creating products that give the ultimate bathing experience yet use water sustainably.

save water

VADO **E⁸** flow regulators are designed to regulate and control the flow of water to taps and showers without hampering the performance or the design of the product.

VADO **E⁸ H₂O**
products can save
up to **80%**
water usage

save money

In an average household VADO **E⁸** delivers a potential £360 saving on utility bills in one year*

*source: VADO study

**Potential £360
saving on utility
bills in one year**

In commercial applications the savings are even greater. The Marriott Hotel group saved almost 41,000 litres of water resulting in an annual reduction of £38,000 in costs after installing VADO **E⁸** flow regulators in one hotel.



save the planet

We all want to try and do what we can to help protect the environment. With VADO **E⁸** flow regulators fitted to your taps and showers, the savings in water, gas and electricity can reduce your carbon footprint.

This can only be good for the planet.



how to order

Every VADO tap or shower that can be fitted with a VADO  flow regulator has the  logo next to it in this catalogue, along with the appropriate product code for the flow regulator that you need to order to achieve water saving.

For example:

to save up to 60% water usage on an AQUABLADE shower head you order:
 AQB-RO/20-C/P
 and
 FR-FLEXI/5-PLA



to save up to 60% water usage on a
 CELSIUS wall mounted thermostatic valve 3/4" with multi function low pressure slide rail shower kit you order:
 CEL-1701-3/4-11-C/P
 and
 FR-SHOWER/9-C/P
 (see page 33)



to save up to 60% water usage on a
 VELO thermostatic valve with integrated diverter and rigid riser with single function shower head and shower handset you order:
 VEL-149RRK/DIV/ST-CP
 and
 2x FR-SHOWER/9-C/P
 (see page 31)



environmental

VADO is not only committed to water saving initiatives but also takes a proactive approach to caring for the environment in other areas too.

ISO 14001

VADO is committed to environmental performance by taking a holistic approach in measuring and setting objectives in line with ISO14001.



Carbon footprint reduction

VADO recognises the importance of measuring its carbon footprint and continually aims to reduce its carbon footprint across all its business operations.



Green Achiever

VADO has been a Green Achiever since 2008. The Green Achiever Award was created to aid companies that act to reduce their impact on the environment.



Recycling

VADO has been recognised as an organisation committed to effective recycling and awarded a certificate in recognition of this by one of the country's leading recycling firms.

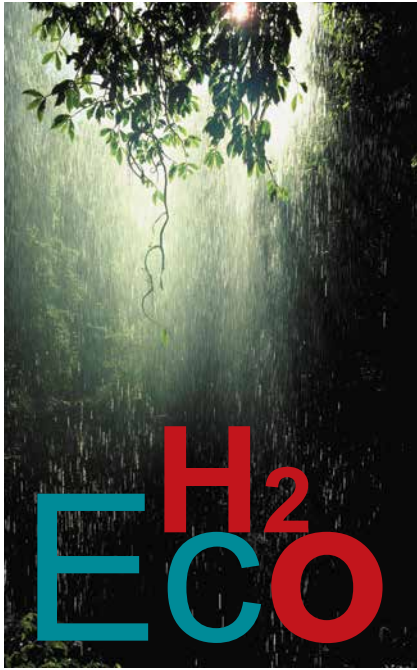

it's a personal experience



showering systems identification guide

in order to choose a showering system that will work at its optimum performance you need to identify the type of plumbing system that is installed in your home

low pressure systems

LP Is there a hot water storage cylinder in the airing cupboard and a cold water tank in the loft?

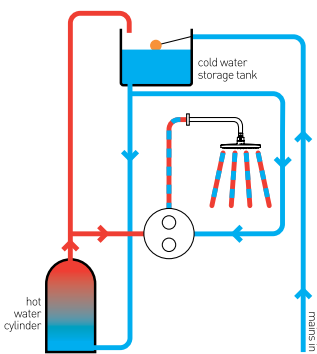

If your system is gravity fed you will typically find a tank in your loft.

If you are running this system without a pump you can choose any shower system with this LP symbol next to it.



cold water tank installed in the loft

combination boilers

MP Is there a boiler, usually located in the kitchen, but no hot water storage cylinder?

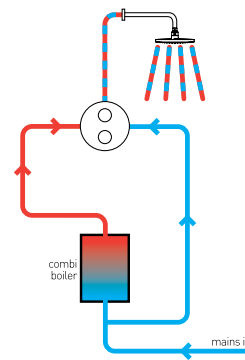

Combination boilers instantly heat mains fed cold water and so do not require any storage tanks. If you have a combination boiler you can choose any shower system with this MP symbol next to it.

Shower systems suitable for gravity fed installations can be used with combination boilers.

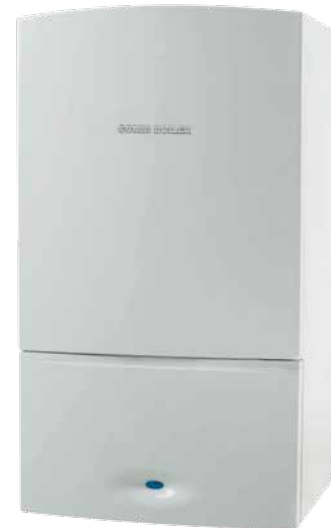

unvented cylinders

HP Is there a hot water cylinder in the airing cupboard with an expansion tank on top and no cold water tank in the loft?

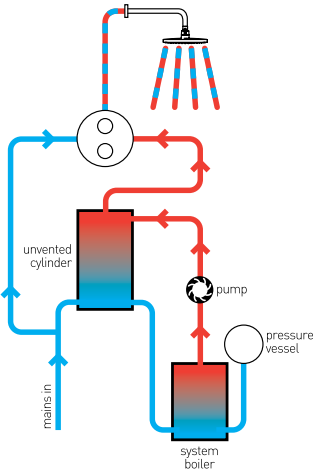

If your system is an unvented cylinder then you can choose any shower system with this HP symbol next to it.

Shower systems suitable for gravity fed and combi boilers can also be used on a high pressure system.



pumped systems

HP Is there a booster pump fitted, similar to this shown below, and a cold water tank in the loft?

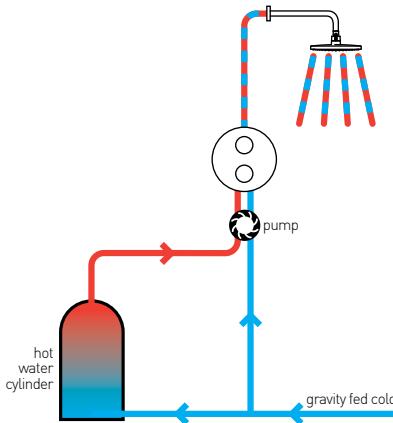

it's a personal experience



contents

concealed valve packages

concealed 2 outlet packages



The perfect showering solution for your bathroom can be selected from our comprehensive collection of thermostatic showering packages.

concealed 1 outlet packages



concealed 2 outlet thermostatic shower valve packages



concealed 2 outlet

shown opposite:
 TAB-1721/NOT-CP
 NOT-100E/CC-C/P
 MIR-MAG/DM-LIT



tablet altitude vertical

- concealed 2 outlet thermostatic shower valve
- includes fittings for 1/2" and 3/4" pipework
- aquablade 300mm (12") round head with shower arm
- zoo single function mini shower kit with integrated outlet and bracket

0.2 bar LP

TAB-1743/ALT-CP £899.00

FR-SHOWER/9-C/P £10.00 (handset)

FR-FLEXI/5-PLA £4.00 (fixed head)

for technical information see page 52



see page 51

tablet notion vertical

- concealed 2 outlet thermostatic shower valve
- includes fittings for 1/2" and 3/4" pipework
- aquablade 200mm x 300mm (8" x 12") rectangular head with shower arm
- instinct single function mini shower kit with integrated outlet and bracket

1.0 bar MP

TAB-1743/NOT-CP £963.00

FR-SHOWER/9-C/P £10.00 (handset)

FR-FLEXI/5-PLA £4.00 (fixed head)

for technical information see page 52



see page 51



all prices include VAT

to save water just add the code shown next to the symbol to your order (see page 6-7 for further information)

concealed 2 outlet



tablet altitude vertical

- concealed 2 outlet thermostatic shower valve with all-flow function
- includes fittings for 1/2" and 3/4" pipework
- aquablade 300mm (12") round head with shower arm
- zoo single function mini shower kit with integrated outlet and bracket

0.2 bar LP

TAB-1721/ALT-CP £899.00

FR-SHOWER/9-C/P £10.00 (handset)

FR-FLEXI/5-PLA £4.00 (fixed head)

for technical information see page 53



tablet altitude vertical

- concealed 2 outlet thermostatic shower valve with all-flow function
- includes fittings for 1/2" and 3/4" pipework
- aquablade 300mm (12") round head with shower arm
- atmosphere slide rail shower kit with air-injection single function handset
- life wall outlet

0.2 bar LP

TAB-1720/ALT-AS-CP £989.00

FR-SHOWER/9-C/P £10.00 (handset)

FR-FLEXI/5-PLA £4.00 (fixed head)

for technical information see page 53





tablet notion vertical

- concealed 2 outlet thermostatic shower valve with all-flow function
- includes fittings for 1/2" and 3/4" pipework
- aquablade 200mm x 300mm (8" x 12") rectangular head with shower arm
- instinct single function mini shower kit with integrated outlet and bracket

1.0 bar MP

TAB-1721/NOT-CP £963.00

⌘ FR-SHOWER/9-C/P £10.00 (handset)

⌘ FR-FLEXI/5-PLA £4.00 (fixed head)

for technical information see page 54



tablet notion vertical

- concealed 2 outlet thermostatic shower valve with all-flow function
- includes fittings for 1/2" and 3/4" pipework
- aquablade 200mm x 300mm (8" x 12") rectangular head with shower arm
- V2 slide rail shower kit with single function handset
- instinct wall outlet

0.2 bar LP

TAB-1720/NOT-V2-CP £989.00

⌘ FR-SHOWER/9-C/P £10.00 (handset)

⌘ FR-FLEXI/5-PLA £4.00 (fixed head)

for technical information see page 54



all prices include VAT

to save water just add the code shown next to the ⌘ symbol to your order (see page 6-7 for further information)

concealed 2 outlet



notion

- concealed 2 outlet thermostatic shower valve
- includes fittings for 1/2" and 3/4" pipework
- aquablade 200mm (8") square head with shower arm
- instinct single function mini shower kit with integrated outlet and bracket

1.0 bar MP

WG-NOTBOX/4/A-C/P £735.00

EB FR-SHOWER/9-C/P £10.00 (handset)

EB FR-FLEXI/5-PLA £4.00 (fixed head)

for technical information see page 55



see page 51

celsius

- round concealed 2 outlet thermostatic shower valve
- includes fittings for 1/2" and 3/4" pipework
- saturn 254mm (10") round head with shower arm
- zoo single function mini shower kit with integrated outlet and bracket

1.0 bar MP

WG-CELBOX/4-C/P £712.00

EB FR-SHOWER/9-C/P £10.00 (2 are required)

for technical information see page 55



see page 51





adjustable fixing
for easy retro fit

celsius

- round concealed 2 outlet thermostatic shower valve
- includes fittings for 1/2" and 3/4" pipework
- saturn 254mm (10") round head with shower arm
- venus single function slide rail shower kit
- elements wall outlet

1.0 bar MP

CEL-1720-12-C/P £769.00

EBB FR-SHOWER/9-C/P £10.00 (2 are required)

for technical information see page 55



see page 51

notion

- concealed 2 outlet thermostatic shower valve
- includes fittings for 1/2" and 3/4" pipework
- aquablade 200mm (8") square head with shower arm
- V2 single function slide rail shower kit
- instinct wall outlet

1.0 bar MP

WG-NOTBOX/2/A-C/P £859.00

EBB FR-SHOWER/9-C/P £10.00 (handset)

EBB FR-FLEXI/5-PLA £4.00 (fixed head)

for technical information see page 56



see page 51



all prices include VAT

valve technology - see page 50

to save water just add the code shown next to the EBB symbol to your order (see page 6-7 for further information)

concealed 2 outlet

shown opposite:
WG-LIFBOX/4-C/P



life

- concealed 2 outlet thermostatic shower valve
- includes fittings for 1/2" and 3/4" pipework
- aquablade 300mm x 200mm (12" x 8") oval head with shower arm
- life single function slide rail shower kit
- life wall outlet

1.0 bar MP

WG-LIFBOX/2-C/P £859.00

£86 FR-SHOWER/9-C/P £10.00 (handset)

£86 FR-FLEXI/5-PLA £4.00 (fixed head)

for technical information see page 56



see page 51

life

- concealed 2 outlet thermostatic shower valve
- includes fittings for 1/2" and 3/4" pipework
- aquablade 300mm x 200mm (12" x 8") oval head with shower arm
- life single function mini shower kit with integrated outlet and bracket

1.0 bar MP

WG-LIFBOX/4-C/P £735.00

£86 FR-SHOWER/9-C/P £10.00 (handset)

£86 FR-FLEXI/5-PLA £4.00 (fixed head)

for technical information see page 56



see page 51



all prices include VAT

valve technology - see page 50

to save water just add the code shown next to the £86 symbol to your order (see page 6-7 for further information)



concealed 2 outlet



mix²

- concealed 2 outlet thermostatic shower valve
- includes fittings for 1/2" and 3/4" pipework
- atmosphere 200mm (8") square head with shower arm
- instinct single function mini shower kit with integrated outlet and bracket

1.0 bar MP

MIX-1721-C/P £799.00

FR-SHOWER/9-C/P £10.00 (handset)

FR-FLEXI/5-PLA £4.00 (fixed head)

for technical information see page 57



see page 51

celsius

- round concealed 2 outlet thermostatic shower valve
- includes fittings for 1/2" and 3/4" pipework
- atmosphere 200mm (8") round head with shower arm
- zoo single function mini shower kit with integrated outlet and bracket

1.0 bar MP

CEL-1721/RO-C/P £779.00

FR-SHOWER/9-C/P £10.00 (handset)

FR-FLEXI/5-PLA £4.00 (fixed head)

for technical information see page 57



see page 51



all prices include VAT

valve technology - see page 50

to save water just add the code shown next to the **FR** symbol to your order (see page 6-7 for further information)

shown below:
WG-81552-C/P

celsius

- square concealed 2 outlet thermostatic shower valve
- includes fittings for 1/2" and 3/4" pipework
- evolve 4 function slide rail shower kit
- elements wall outlet
- bath filler waste and overflow

1.5 bar MP
 CEL-1723-21-C/P €879.00
 €88 FR-SHOWER/9-C/P €10.00

for technical information see page 57



adjustable fixing
for easy retro fit



concealed 2 outlet

concealed 1 outlet thermostatic
shower valve packages



shown opposite:
CEL-1710-21-C/P



air injection technology

tablet altitude vertical

- concealed 1 outlet thermostatic shower valve
- includes fittings for 1/2" and 3/4" pipework
- atmosphere slide rail shower kit with air-injection single function handset
- life wall outlet

0.2 bar LP
TAB-1710/ALT-AS-CP £633.00
E8 FR-SHOWER/9-C/P £10.00

for technical information see page 58



notion

- concealed 1 outlet thermostatic shower valve
- includes fittings for 1/2" and 3/4" pipework
- aquablade 200mm (8") square head with shower arm

0.2 bar LP
WG-NOTBOX/A-C/P £549.00
E8 FR-FLEXI/5-PLA £4.00

for technical information see page 58



celsius

- round concealed 1 outlet thermostatic shower valve
- includes fittings for 1/2" and 3/4" pipework
- saturn 254mm (10") round head with shower arm

0.5 bar LP
WG-CELBOXRO/SAT-C/P £538.00
E8 FR-SHOWER/9-C/P £10.00

for technical information see page 58



all prices include VAT

valve technology - see page 50

to save water just add the code shown next to the E8 symbol to your order (see page 6-7 for further information)

concealed 1 outlet

celsius

- round concealed 1 outlet thermostatic shower valve
- includes fittings for 1/2" and 3/4" pipework
- evolve 4 function slide rail shower kit
- elements wall outlet

0.2 bar LP

CEL-1710-11-C/P €582.00

FR-SHOWER/9-C/P €10.00

for technical information see page 59



see page 51



celsius

- square concealed 1 outlet thermostatic shower valve
- includes fittings for 1/2" and 3/4" pipework
- evolve 4 function slide rail shower kit
- elements wall outlet

0.2 bar LP

CEL-1710-21-C/P €582.00

FR-SHOWER/9-C/P €10.00

for technical information see page 59



see page 51

life

- concealed 1 outlet thermostatic shower valve
- includes fittings for 1/2" and 3/4" pipework
- evolve 4 function slide rail shower kit
- life wall outlet

0.2 bar LP

LIF-1710-31-C/P £582.00

 FR-SHOWER/9-C/P £10.00

for technical information see page 59



 adjustable fixing
for easy retro fit



notion

- concealed 1 outlet thermostatic shower valve
- includes fittings for 1/2" and 3/4" pipework
- V2 single function slide rail shower kit
- instinct wall outlet

0.2 bar LP

WG-NOTBOX/5-C/P £582.00

 FR-SHOWER/9-C/P £10.00

for technical information see page 59



all prices include VAT

valve technology - see page 50

to save water just add the code shown next to the  symbol to your order (see page 6-7 for further information)

thermostatic
shower valve
with rigid riser
packages



shown opposite:
STRA-149/RRK-W/C



new

strata

- thermostatic shower valve with integrated diverter and rigid riser
- glass topped valve doubles as a shelf
- saturn 254mm (10") round shower head
- nebula round 3 function shower handset

1.0 bar MP

STRA-149/RRK-W/C £765.00

EBB FR-SHOWER/9-C/P £10.00 (2 are required)

for technical information see page 60



new

phase

- thermostatic shower valve with integrated diverter and rigid riser
- aquablade 300mm x 200mm rectangular shower head
- nebula square 3 function shower handset

1.0 bar MP

PHA-149/RRK-C/P £712.00

EBB FR-SHOWER/9-C/P £10.00 (handset)

EBB FR-FLEXI/5-PLA £4.00 (fixed head)

for technical information see page 60



all prices include VAT

to save water just add the code shown next to the EBB symbol to your order (see page 6-7 for further information)

rigid risers



celsius

- round concealed thermostatic shower valve
- includes fittings for 1/2" and 3/4" pipework
- rigid riser shower kit with integrated diverter
- saturn 254mm (10") round shower head
- atmosphere air-injection single function shower handset

1.0 bar MP
 WG-CELBOXRO/RRK-C/P €824.00
 E86 FR-SHOWER/9-C/P €10.00 (2 are required)

for technical information see page 61



see page 51



notion

- concealed thermostatic shower valve
- includes fittings for 1/2" and 3/4" pipework
- rigid riser shower kit with integrated diverter
- 200mm (8") square shower head
- single function shower handset

1.0 bar MP
 WG-CELBOXNOT/RRK-C/P €824.00
 E86 FR-SHOWER/9-C/P €10.00 (2 are required)

for technical information see page 61



see page 51





velo aquablade

- square thermostatic shower valve with integrated diverter and rigid riser
- aquablade 300mm x 200mm (12" x 8") rectangular shower head
- aquablade square single function shower handset

1.5 bar MP
 VEL-149/RRKSQ/AQB-CP £499.00
 EBo FR-FLEXI/5-PLA £4.00 (2 are required)

for technical information see page 61



velo aquablade

- round thermostatic shower valve with integrated diverter and rigid riser
- aquablade 300mm (12") round shower head
- aquablade round single function shower handset

1.5 bar MP
 VEL-149/RRKRO/AQB-CP £499.00
 EBo FR-FLEXI/5-PLA £4.00 (2 are required)

for technical information see page 62



all prices include VAT

to save water just add the code shown next to the EBo symbol to your order (see page 6-7 for further information)

rigid risers



velo atmosphere

- round thermostatic shower valve with integrated diverter and rigid riser
- atmosphere 200mm (8") round shower head
- atmosphere air-injection 5 function shower handset

1.5 bar MP

VEL-149/RRKRO/ATM-CP £499.00

FR-SHOWER/9-C/P £10.00 (handset)

FR-FLEXI/5-PLA £4.00 (fixed head)

for technical information see page 62



vertex

- round thermostatic shower valve with integrated diverter and rigid riser
- saturn 254mm (10") round shower head
- single function shower handset

1.5 bar MP

VER-149/RO/RRK-C/P £493.00

FR-SHOWER/9-C/P £10.00 (2 are required)

for technical information see page 62





velo

- round thermostatic shower valve with integrated diverter and rigid riser
- saturn 254mm (10") round shower head
- atmosphere air-injection single function shower handset

1.5 bar MP
 VEL-149RRK/DIV/ST-CP £499.00
 E8o FR-SHOWER/9-C/P £10.00 (2 are required)

for technical information see page 63



velo

- square thermostatic shower valve with integrated diverter and rigid riser
- 200mm (8") square shower head
- single function shower handset

1.5 bar MP
 VEL-149/RRKSQ/DIV-CP £499.00
 E8o FR-SHOWER/9-C/P £10.00 (2 are required)

for technical information see page 63



all prices include VAT

to save water just add the code shown next to the E8o symbol to your order (see page 6-7 for further information)

exposed thermostatic
shower valve packages



shown opposite:
CEL-1701-3/4-11-C/P



té

- exposed thermostatic 1/2" shower valve
- V2 single function slide rail shower kit
- wall mounting brackets

0.2 bar LP
WG-TEBOX149/B-1/2-CP €378.00
WG-TEBOX149-1/2-C/P €355.00 without wall mounting brackets
Eco FR-SHOWER/9-C/P €10.00

for technical information see page 64



celsius

- round exposed thermostatic 3/4" shower valve
- evolve 4 function slide rail shower kit
- wall mounting brackets

0.2 bar LP
CEL-1701-3/4-11-C/P €362.00
CEL-1700-3/4-11-C/P €339.00 without wall mounting brackets
Eco FR-SHOWER/9-C/P €10.00

for technical information see page 64



celsius

- round exposed thermostatic 1/2" shower valve
- evolve 4 function slide rail shower kit
- wall mounting brackets

0.2 bar LP
CEL-1701-1/2-11-C/P €339.00
CEL-1700-1/2-11-C/P €316.00 without wall mounting brackets
Eco FR-SHOWER/9-C/P €10.00

for technical information see page 64



all prices include VAT

to save water just add the code shown next to the Eco symbol to your order (see page 6-7 for further information)

exposed valves

shown opposite:
MAJESTIQ/RRK-C/P



prima

- exposed thermostatic 1/2" shower valve
- eris 3 function slide rail shower kit
- wall mounting brackets

0.2 bar LP

PRIMABOX4/B-MF-C/P €249.00

PRIMABOX4-MF-C/P €229.00 without wall mounting brackets

FR-SHOWER/9-C/P €10.00

for technical information see page 65



prima

- exposed thermostatic 1/2" shower valve
- eris single function slide rail shower kit
- wall mounting brackets

0.2 bar LP

PRIMABOX4/B-SF-C/P €229.00

PRIMABOX4-SF-C/P €199.00 without wall mounting brackets

FR-SHOWER/9-C/P €10.00

for technical information see page 65



traditional
thermostatic
shower valve
packages

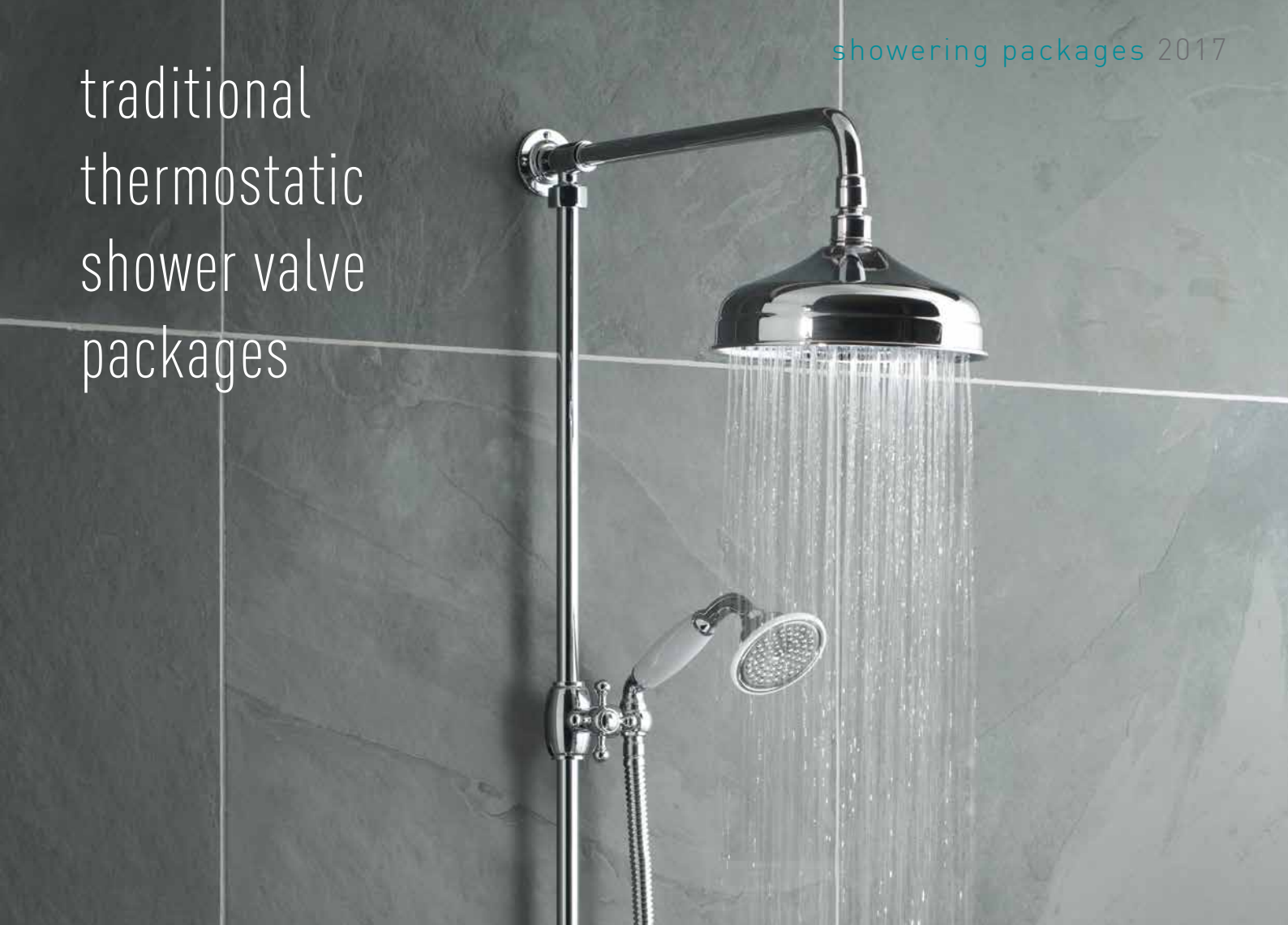

westbury

- traditional exposed thermostatic 3/4" shower valve
- traditional rigid riser shower kit with integrated diverter
- traditional 200mm (8") round shower head

1.0 bar MP

MAJESTIQ/RRK-C/P €1,539.00

EBB FR-SHOWER/9-C/P €10.00 (2 are required)

for technical information see page 65



all prices include VAT

to save water just add the code shown next to the EBB symbol to your order (see page 6-7 for further information)

electric showers



electric showers

The exclusive range of electric showers from VADO featuring advanced shower technology and outstanding design. Choose from our niche range of styles and finishes from the organic natural beauty of Elegance to contemporary Vogue; you can be sure you're giving your bathroom a truly original look and feel.

plumbing requirements

Electric showers connect to a cold mains water supply and heat the water by an element inside the shower providing instant hot water. This makes them 99.7% energy efficient as there is no hot water wastage.

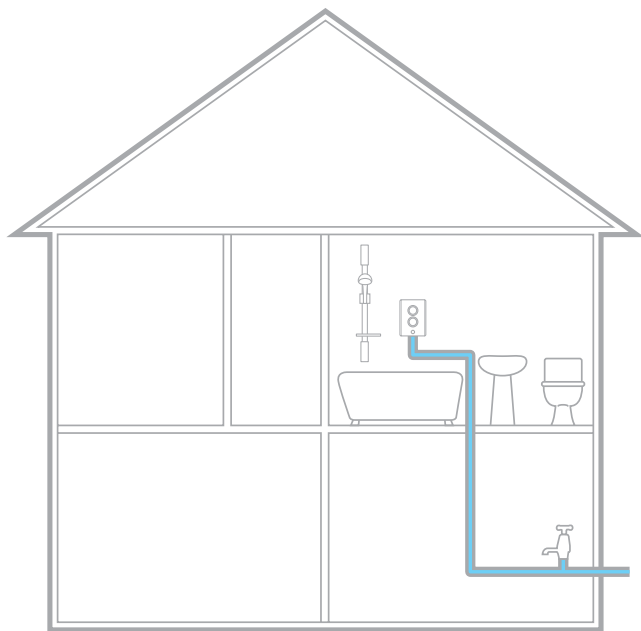

A typical cold mains water system

kilowatt rating explained

The higher the kilowatt power rating (kW) the better the performance and greater the flow of heated water. As a general rule, for every kW rating increase (for example going from 8.5kW to 9.5kW) you should experience a 12.5% increase in flow. Products featured are available as 8.5kW and 9.5kW variants: see chart below detailing the electrical requirements.

electric requirements

Power rating @240V	Power rating @230V	MCB protection rating	Cartridge fuse
8.5 kW	7.9 kW	40A	45A
9.5 kW	8.8 kW	40/45A	45A

Note: Please note all kW stated throughout the guide are at 240V

instantaneous performance

The approximate temperatures indicated are based on ambient incoming water temperature. This can vary between 3°C and 23°C depending on weather conditions.

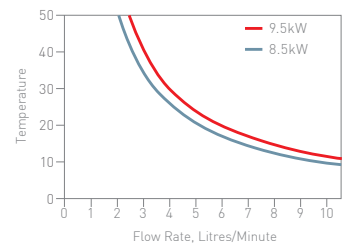

the shower symbols explained



Showers that are suitable for cold mains systems.



When the shower is turned off, the water continues to run for a few seconds to flush out preheated water before stopping completely to help prevent limescale build up.

All electric showers comply with BEAB, CE and BSI Kitemark approvals.



All our electric showers are covered by a two year full parts and labour guarantee for domestic use.



Water inlet to accommodate both left and right hand cable entry points.



vogue



shown opposite:
ELS-VOG-85-BLK



vogue black
ELS-VOG-85-BLK - 8.5kW - £329.00
ELS-VOG-95-BLK - 9.5kW - £347.00

product fiche according to commission delegated regulation (EU) 812/2013

Trade Mark	Vado
Model	ELS-VOG-85-BLK
Load Profile	XS
Energy Efficiency Class	A
Annual Electricity Consumption	482
Thermostat Temperature Settings	57/90°C
Sound Power Level	15

product fiche according to commission delegated regulation (EU) 812/2013

Trade Mark	Vado
Model	ELS-VOG-95-BLK
Load Profile	XS
Energy Efficiency Class	A
Annual Electricity Consumption	483
Thermostat Temperature Settings	57/90°C
Sound Power Level	15

Contemporary electric shower featuring easy-to-use touch controls with a clear illuminated display and a phased shutdown function which helps to reduce limescale build-up. Comes complete with slide rail kit, anti-kink chrome hose and easy clean shower head with 5 spray patterns.

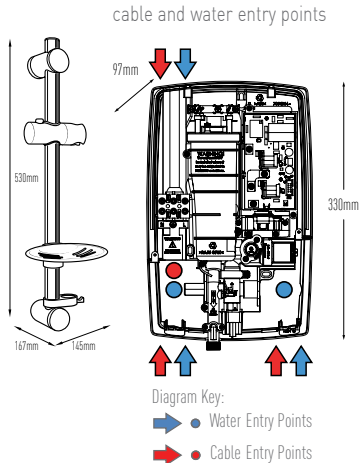
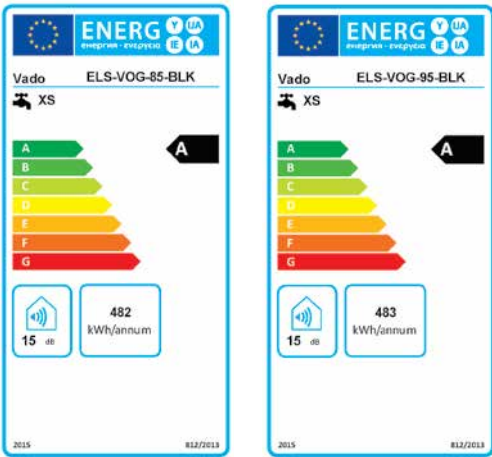

all prices include VAT

elegance



elegance bronze

ELS-ELE-85-BRZ - 8.5kW - £274.00

ELS-ELE-95-BRZ - 9.5kW - £292.00





elegance black speckled
 ELS-ELE-85-BLS - 8.5kW - £274.00
 ELS-ELE-95-BLS - 9.5kW - £292.00



elegance grey
 ELS-ELE-85-GRE - 8.5kW - £274.00
 ELS-ELE-95-GRE - 9.5kW - £292.00



elegance metallic
 ELS-ELE-85-MET - 8.5kW - £274.00
 ELS-ELE-95-MET - 9.5kW - £292.00

* product fiche according to commission delegated regulation (EU) 812/2013

Trade Mark	Vado
Model	ELS-ELE-85-MET
Load Profile	XS
Energy Efficiency Class	A
Annual Electricity Consumption	482
Thermostat Temperature Settings	50/57/90°C
Sound Power Level	15

* product fiche according to commission delegated regulation (EU) 812/2013

Trade Mark	Vado
Model	ELS-ELE-95-MET
Load Profile	XS
Energy Efficiency Class	A
Annual Electricity Consumption	483
Thermostat Temperature Settings	50/57/90°C
Sound Power Level	15

A fashion-led, modern design electric shower with soft press illuminated buttons, start/stop switch, power on indicator, low pressure indicator and phased shutdown feature which helps to reduce limescale build-up. Comes complete with slide rail kit, anti-kink chrome hose and easy clean shower head with 5 spray patterns.

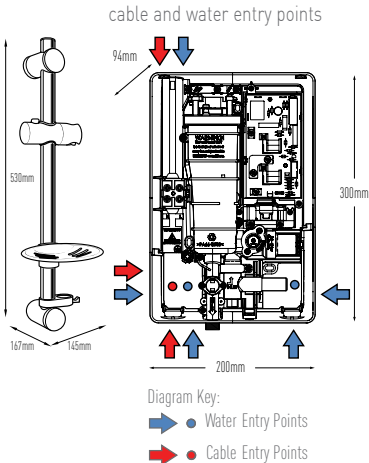
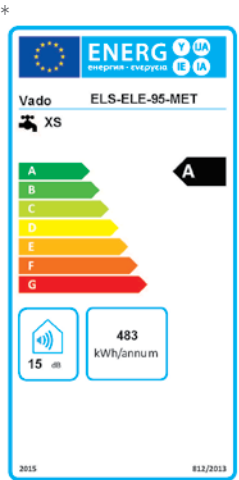

2 TWO YEAR GUARANTEE
 C COLD MAINS SUITABLE
 PHASED SHUTDOWN
 EASY PLUMB

BEAB Approved CE

all prices include VAT

*energy and fiche information applicable to all colours in elegance range

digital remote



digital remote
ELS-DIG-95-CP - 9.5kW - £534.00

**product fiche according to commission
delegated regulation (EU) 812/2013**

Trade Mark	Vado
Model	ELS-DIG-95-CP
Load Profile	XS
Energy Efficiency Class	A
Annual Electricity Consumption	483
Thermostat Temperature Settings	50/57/90°C
Sound Power Level	15

Digital electric shower featuring a separate control panel which operates up to 3.5m away from the power pack. The power pack can be hidden in your loft, airing cupboard or under a bath. Featuring a start/stop button with phased shutdown to help prevent limescale build-up, push button power selectors, temperature control with numbered dial and low pressure indicator. Comes with wall outlet, slide rail kit, anti-kink chrome hose and easy clean shower head with 5 spray patterns.

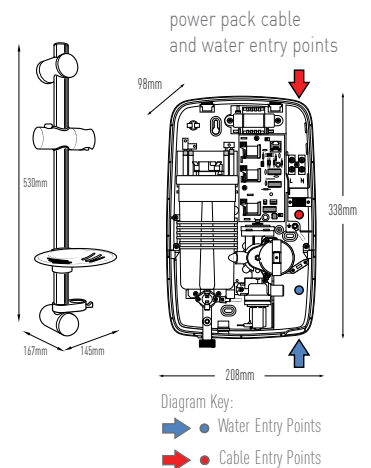
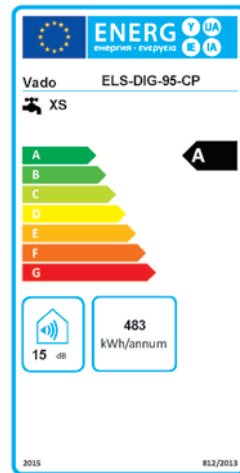

all chrome



all chrome
 ELS-CHR-85-CP - 8.5kW - £285.00
 ELS-CHR-95-CP - 9.5kW - £299.00

product fiche according to commission delegated regulation (EU) 812/2013

Trade Mark	Vado
Model	ELS-CHR-85-CP
Load Profile	XS
Energy Efficiency Class	A
Annual Electricity Consumption	482
Thermostat Temperature Settings	50/57/90°C
Sound Power Level	15

product fiche according to commission delegated regulation (EU) 812/2013

Trade Mark	Vado
Model	ELS-CHR-95-CP
Load Profile	XS
Energy Efficiency Class	A
Annual Electricity Consumption	483
Thermostat Temperature Settings	50/57/90°C
Sound Power Level	15

A stylish, all-chrome, slimline electric shower. Featuring a start/stop button with phased shutdown to help prevent limescale build-up, push button power selectors, temperature control with numbered dial and low pressure indicator. Comes complete with slide rail kit, anti-kink chrome hose and easy clean shower head with 5 spray patterns.

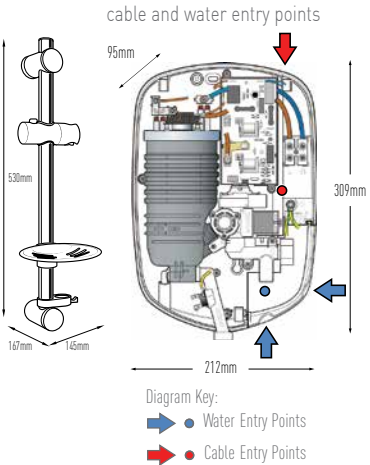
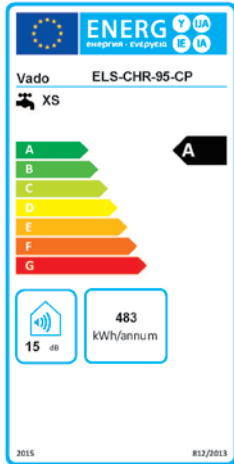
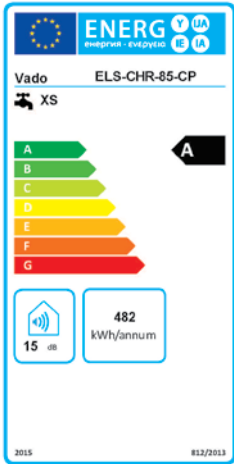

all prices include VAT

black chic



electric showers

shown opposite:
ELS-CHI-85-BLK



black chic
ELS-CHI-85-BLK - 8.5kW - £182.00
ELS-CHI-95-BLK - 9.5kW - £198.00

product fiche according to commission delegated regulation (EU) 812/2013

Trade Mark	Vado
Model	ELS-CHI-85-BLK
Load Profile	XS
Energy Efficiency Class	A
Annual Electricity Consumption	482
Thermostat Temperature Settings	48/75°C
Sound Power Level	15

product fiche according to commission delegated regulation (EU) 812/2013

Trade Mark	Vado
Model	ELS-CHI-95-BLK
Load Profile	XS
Energy Efficiency Class	A
Annual Electricity Consumption	483
Thermostat Temperature Settings	48/75°C
Sound Power Level	15

All black electric shower featuring single control for both temperature and flow, illuminated start/stop button and a power on indicator. Comes complete with slide rail kit, anti-kink chrome hose and easy clean single function shower head.

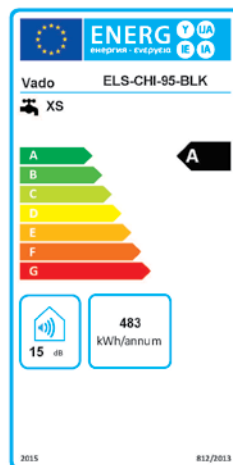

cable and water entry points

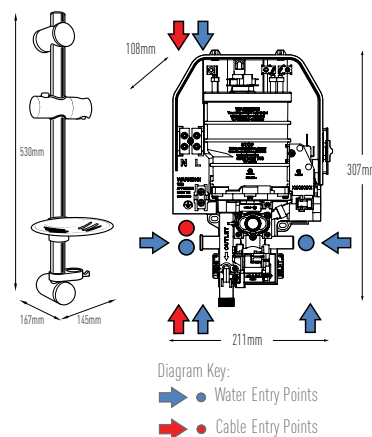

baskets



shown opposite:
BAS-2016M-C/P

removable corner basket
185 (w) x 185 (d) x 60mm (h)
BAS-2000-C/P £95.00

for technical information see page 66



small triangular corner basket
150 (w) x 114 (d) x 36mm (h)
BAS-2015S-C/P £36.00

for technical information see page 66

medium triangular corner basket
220 (w) x 147 (d) x 65mm (h)
BAS-2015M-C/P £46.00

for technical information see page 66

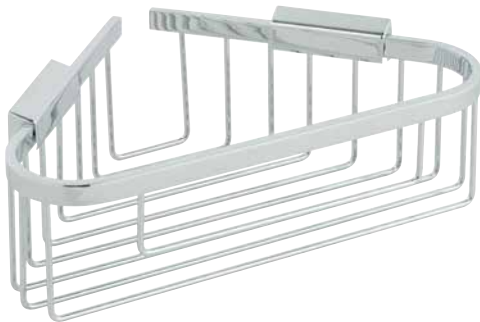
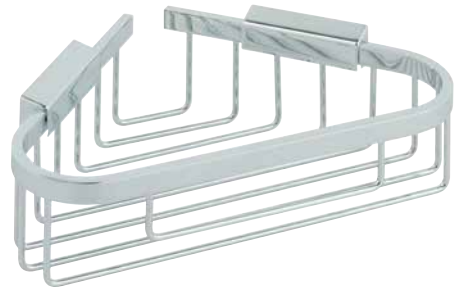

large triangular corner basket
260 (w) x 164 (d) x 85mm (h)
BAS-2015L-C/P £98.00

for technical information see page 66

large triangular corner basket
270 (w) x 194 (d) x 105mm (h)
BAS-2012-C/P £85.00

for technical information see page 66



baskets



corner basket with hook
206 (w) x 206 (d) x 90mm (h)
BAS-2014-C/P £119.00

for technical information see page 66

small rectangular basket
135 (w) x 103 (d) x 37mm (h)
BAS-2001-C/P £36.00

for technical information see page 66



medium rectangular basket
210 (w) x 128 (d) x 37mm (h)
BAS-2002-C/P £42.00

for technical information see page 67

medium rectangular basket
210 (w) x 128 (d) x 65mm (h)
BAS-2016M-C/P £59.00

for technical information see page 67

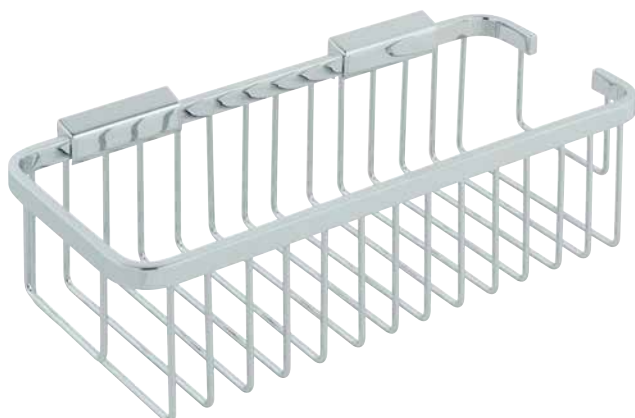
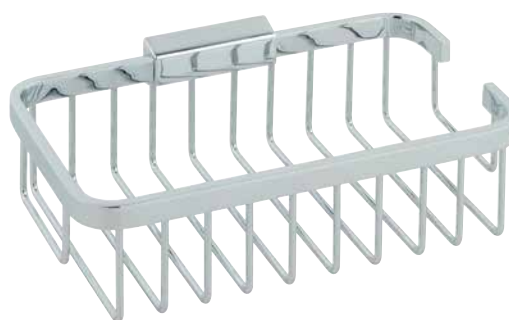

large rectangular basket
300 (w) x 138 (d) x 85mm (h)
BAS-2016L-C/P £73.00

for technical information see page 67

large double triangular corner basket
200 (w) x 160 (d) x 206mm (h)
BAS-2013-C/P €98.00

for technical information see page 67



large rectangular double basket
304 (w) x 140 (d) x 484mm (h)
BAS-2003-C/P €179.00

for technical information see page 67

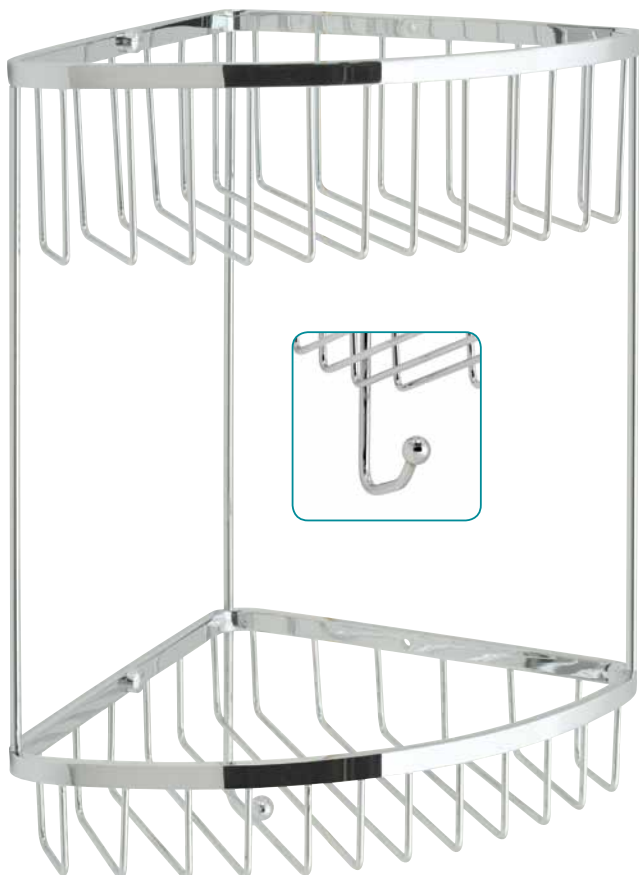

large double triangular corner basket
with integral hook
269 (w) x 196 (d) x 368mm (h)
BAS-2004-C/P €127.00

for technical information see page 67

thermostatic valves explained

VADO's improved range of concealed thermostatic valves

Our polymer based cartridges are highly resistant to limescale deposits

diverter cartridge that is resistant to limescale build up and manages plumbing debris more effectively

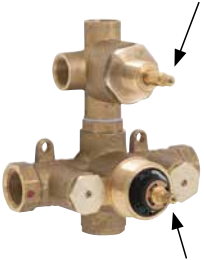

polymer thermostatic cartridge that is resistant to limescale



compact rectangular backplate with soft round corners for celsius SQ valves for a sleek finish



compact rectangular backplates for notion and mix² valves for a sleeker finish



mortar guard complete with markings to aid installation and tiling

the mortar guard is now supplied with all concealed 2 handle thermostatic shower valves

tablet thermostatic shower valves



All 2 and 3 outlet models feature an exclusive 'all-flow' function that delivers water to either outlet independently or all outlets simultaneously.

High flow internal waterways ensure an outstanding performance even at low pressure.

simple to fit

- flat back valve body allows for a solid, secure mount
- handles have multiple fitting positions to allow perfect alignment of the handle and shroud
- 25mm fitting depth tolerance. (min 75mm max 100mm).
- Tablet can fit in a 50mm stud wall when using a Studfast bracket
- screw-on shrouds and slide-on plates ensure a rapid and simple second fix
- easy-access isolation points
- the plate size allows for a 10mm tile cutting tolerance

exceptional functionality

- luxurious soft-turn handles
- exceptional safety from temperature fluctuations
- excellent flow rates, even at low pressure
- 'all-flow' function

1 flow control

Independently controls the flow of water to two outlets, with additional 'all-flow' function, which enables both outlets to operate simultaneously.

2 temperature control

Smooth and safe pre-set temperature control. The thermostatic cartridge prevents scalding from sudden pressure fluctuations and cold water isolation.

3 flow control

Controls the flow of water to one outlet.



studfast concealed shower valve mounting bracket

studfast is an easy, strong and secure method of mounting VADO thermostatic shower valves into stud walls to create a firm and trouble-free installation

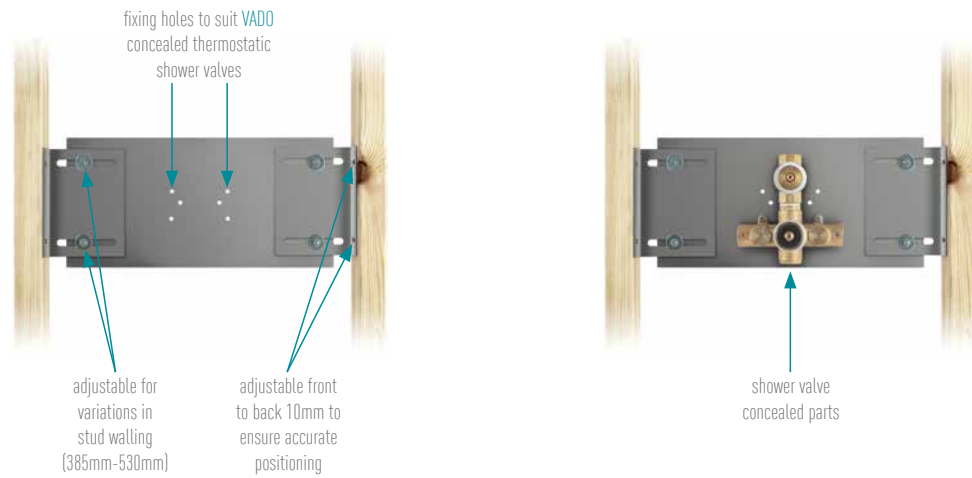

the VADO concealed thermostatic shower valve body bolts onto the studfast bracket creating a firm installation

Look for the  logo which denotes the shower valves suitable for use with the studfast bracket

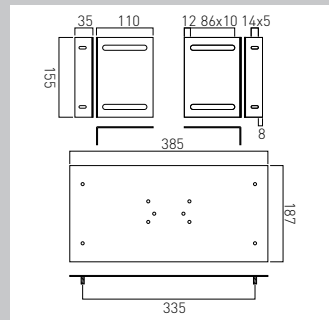

concealed wall bracket for mounting VADO thermostatic shower valves in stud walls

chrome	£ inc-vat
WG-STUDFAST-C-S/S	37.00

shower valve depth calculator

this guide shows how to calculate the depth that your VADO shower valve should be set in the wall to create optimum performance and appearance.

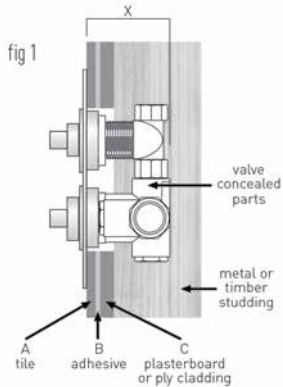

STEP 1
Identify the optimum installation depth (X)

Please look up optimum depth for your chosen shower valve in the following pages, or you can access the same information on our website at www.vado-uk.com

This is represented as X in fig. 1

STEP 2
Calculate the thickness of the finished tile wall (T)

This is the total thickness of your tile plus adhesive plus plasterboard or ply cladding.

This is shown as T in fig.2

Calculation:
 $T = A$ (tile thickness) + B (adhesive thickness, usually 3-5mm) + C (plasterboard or ply cladding thickness)

Example:
If working with a 10mm thick tile, 5mm layer of adhesive, 15mm thick plasterboard
 $T = 10\text{mm} + 5\text{mm} + 15\text{mm} = 30\text{mm}$.
T value is therefore 30mm.

STEP 3
Calculate the depth that you need to fit your valve (D)

This depth is the total distance from the front face of the studwall to the back of the shower valve (or front face of your VADO WG-STUDFAST bracket if you are using the VADO studfast bracket for easier installation). This is shown as D in fig 2

Calculation: $X - T = D$

Example:
If fitting a NOT-148C-C/P the optimum depth (X) is 73mm
In step 2, T was identified as 30mm

D is calculated as:
 $73\text{mm} - 30\text{mm} = 43\text{mm}$.
Therefore you install the valve at a distance of 43mm from the front face of your timber or metal stud wall to the back of the shower valve (or front face of your studfast bracket)

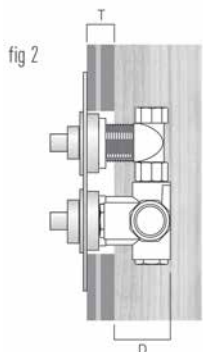

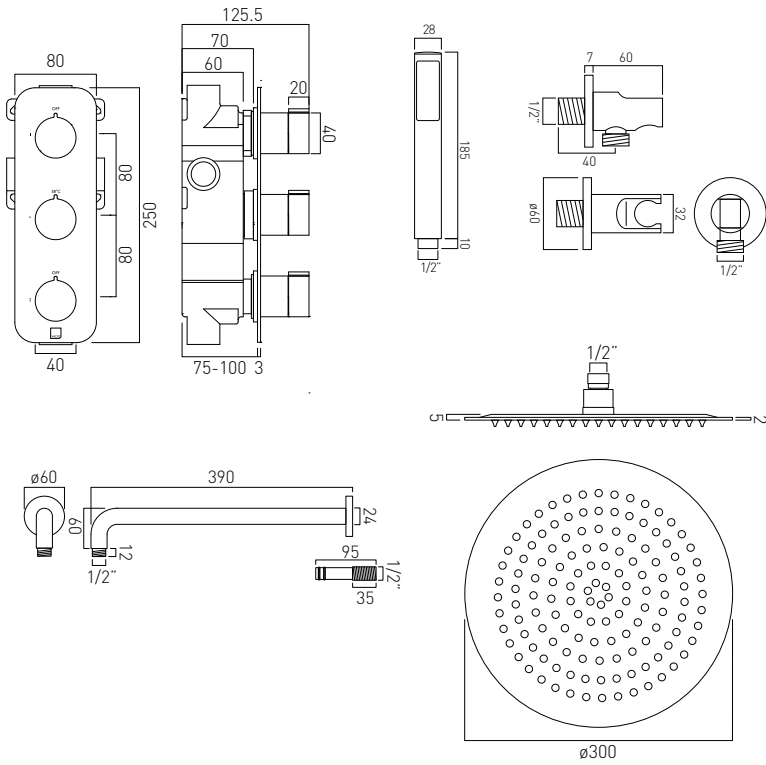

0.2 bar LP
 TAB-1743/ALT-CP £899.00
 FR-SHOWER/9-C/P £10.00 (handset)
 FR-FLEXI/5-PLA £4.00 (fixed head)

optimum valve installation depth 88mm

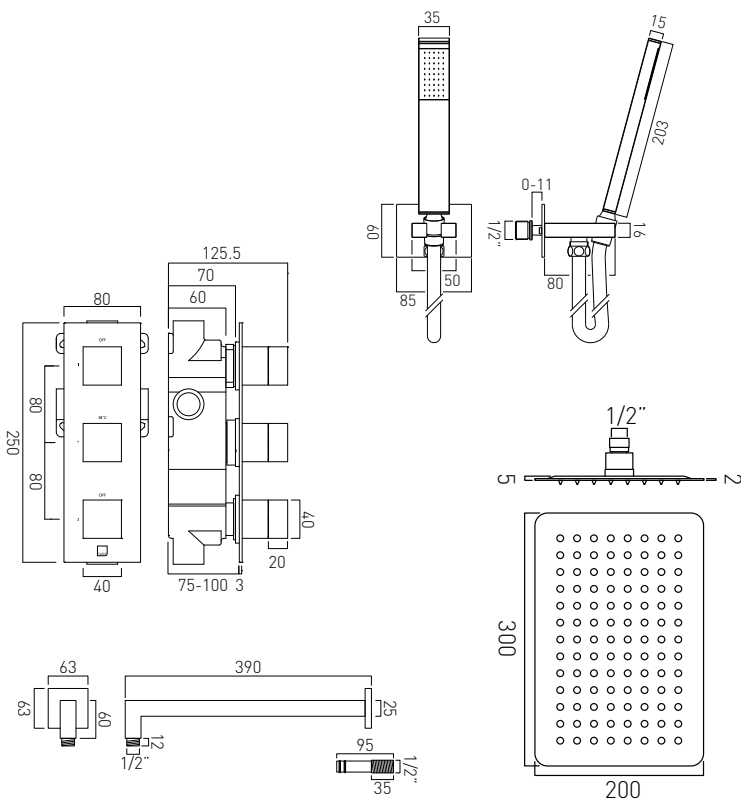

1.0 bar MP
 TAB-1743/NOT-CP £963.00
 FR-SHOWER/9-C/P £10.00 (handset)
 FR-FLEXI/5-PLA £4.00 (fixed head)

optimum valve installation depth 88mm



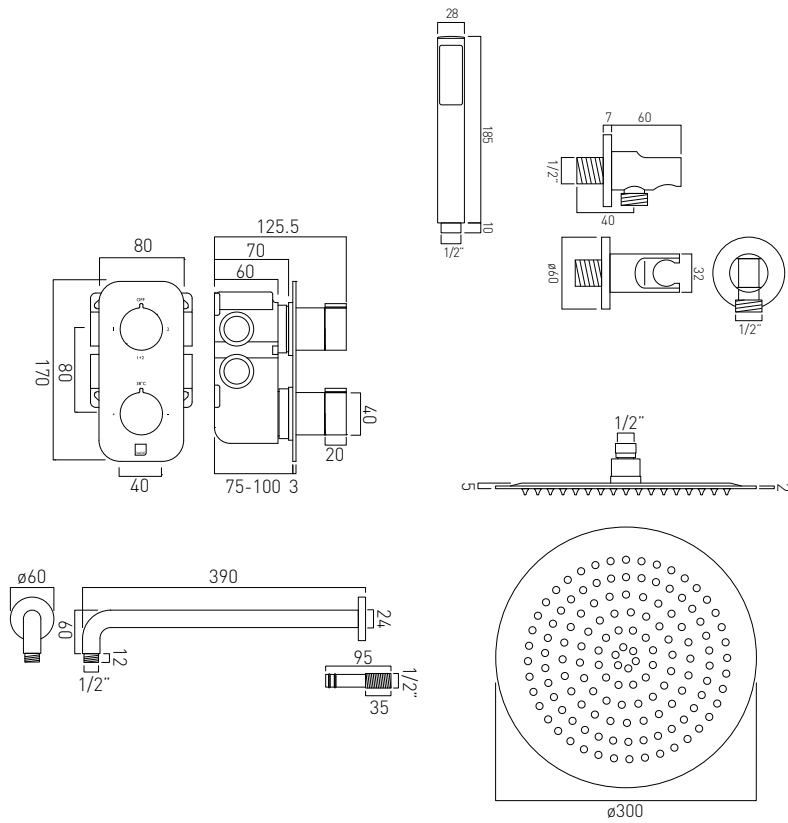

0.2 bar LP
 TAB-1721/ALT-CP £899.00
 £66 FR-SHOWER/9-C/P £10.00 (handset)
 £66 FR-FLEXI/5-PLA £4.00 (fixed head)

optimum valve installation depth 88mm

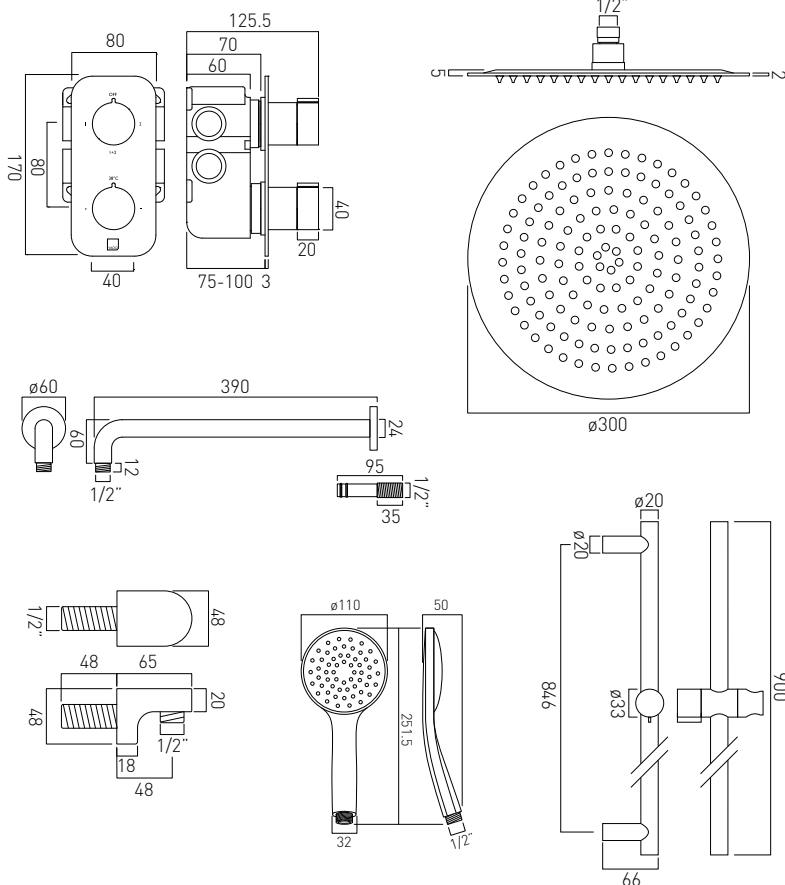

0.2 bar LP
 TAB-1720/ALT-AS-CP £989.00
 £66 FR-SHOWER/9-C/P £10.00 (handset)
 £66 FR-FLEXI/5-PLA £4.00 (fixed head)

optimum valve installation depth 88mm



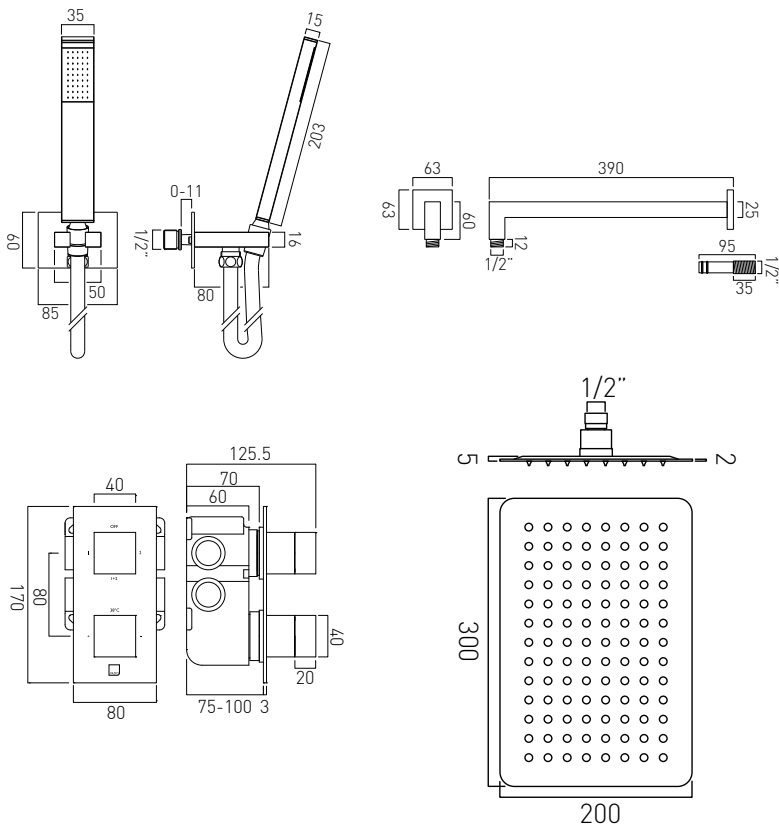

1.0 bar MP
 TAB-1721/NOT-CP E963.00
 FR-SHOWER/9-C/P £10.00 (handset)
 FR-FLEXI/5-PLA £4.00 (fixed head)

optimum valve installation depth 88mm

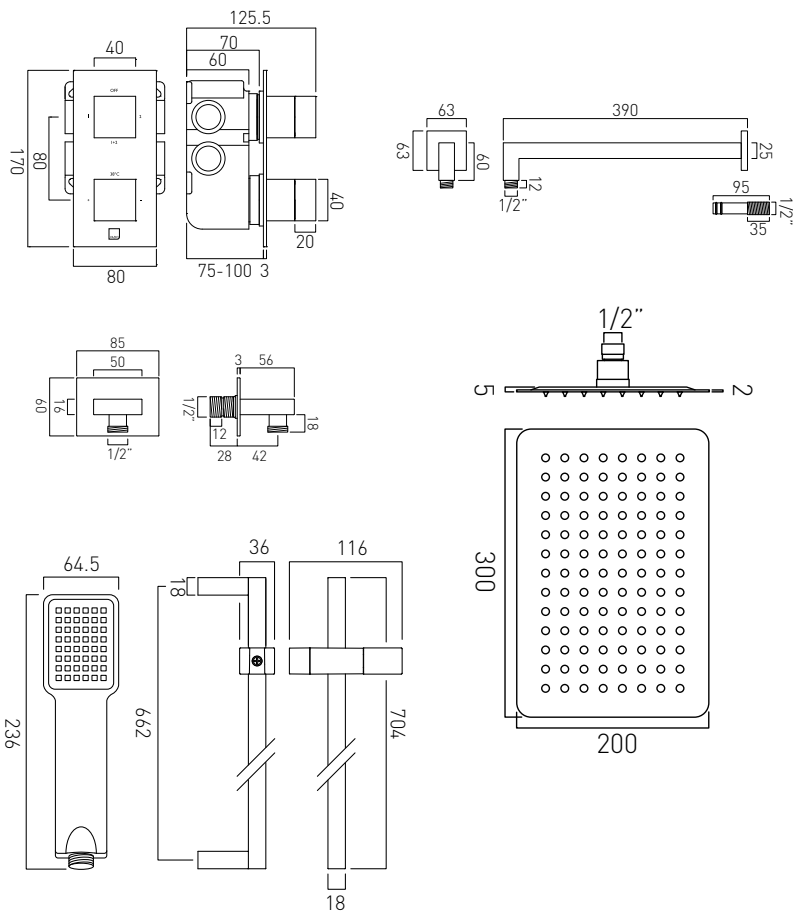

0.2 bar LP
 TAB-1720/NOT-V2-CP E989.00
 FR-SHOWER/9-C/P £10.00 (handset)
 FR-FLEXI/5-PLA £4.00 (fixed head)

optimum valve installation depth 88mm



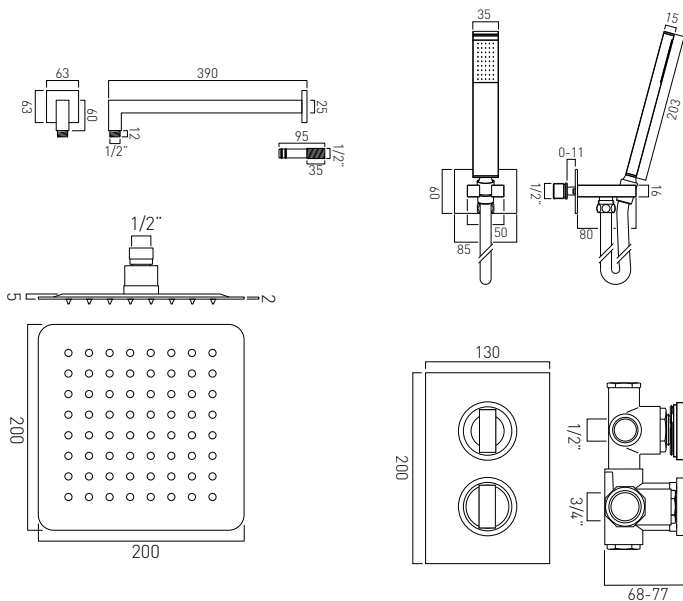

1.0 bar MP
 WG-NOTBOX/4-A-C/P £735.00
 FR-SHOWER/9-C/P £10.00 (handset)
 FR-FLEXI/5-PLA £4.00 (fixed head)

optimum valve installation depth 73mm (standard)
 optimum valve installation depth 90mm (with extension kit below)
 1x NOT-148/2/3/FLOW-EXT £21.00
 1x NOT-148C/TEMP-EXT £21.00
 (both items are required)



see page 51

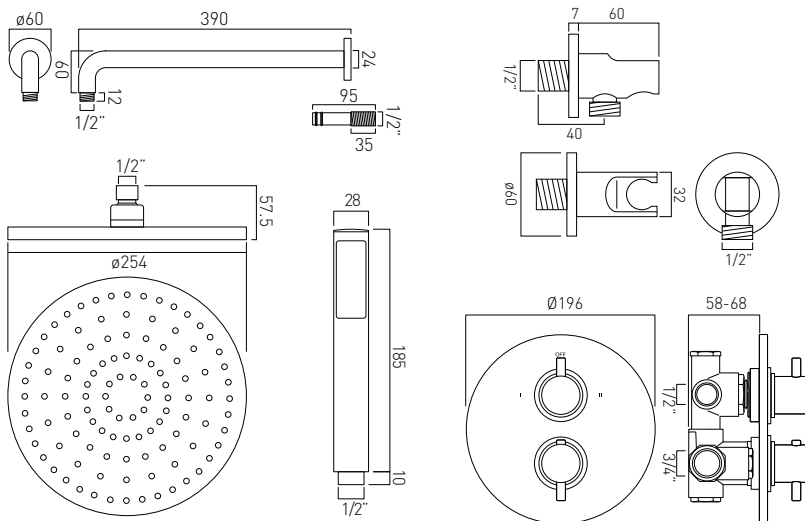

1.0 bar MP
 WG-CELBOX/4-C/P £712.00
 FR-SHOWER/9-C/P £10.00 (2 are required)

optimum valve installation depth 63mm (standard)
 optimum valve installation depth 82mm (with extension kit below)
 1x CEL-148/2/3/FLOW-EXT £21.00
 1x CEL-148C/TEMP-EXT £21.00
 (both items are required)



see page 51

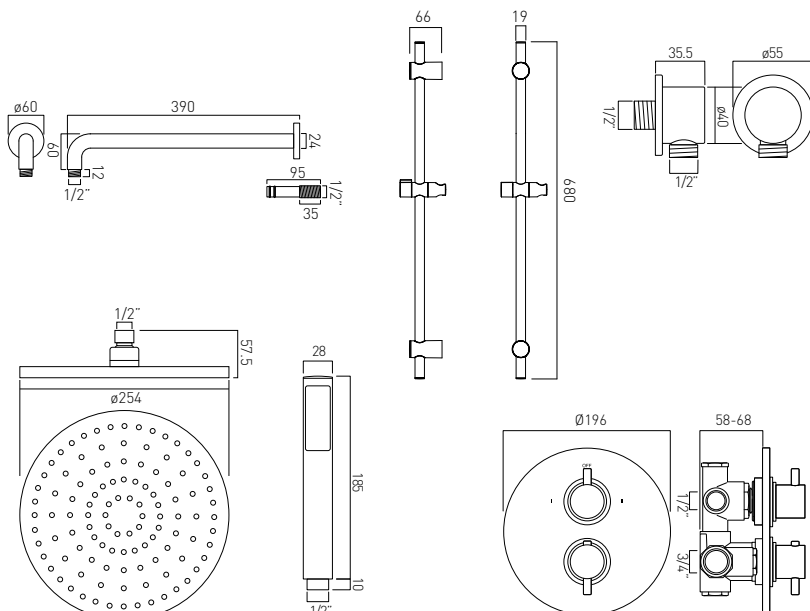

1.0 bar MP
 CEL-1720-12-C/P £769.00
 FR-SHOWER/9-C/P £10.00 (2 are required)

optimum valve installation depth 63mm (standard)
 optimum valve installation depth 82mm (with extension kit below)
 1x CEL-148/2/3/FLOW-EXT £21.00
 1x CEL-148C/TEMP-EXT £21.00
 (both items are required)



see page 51

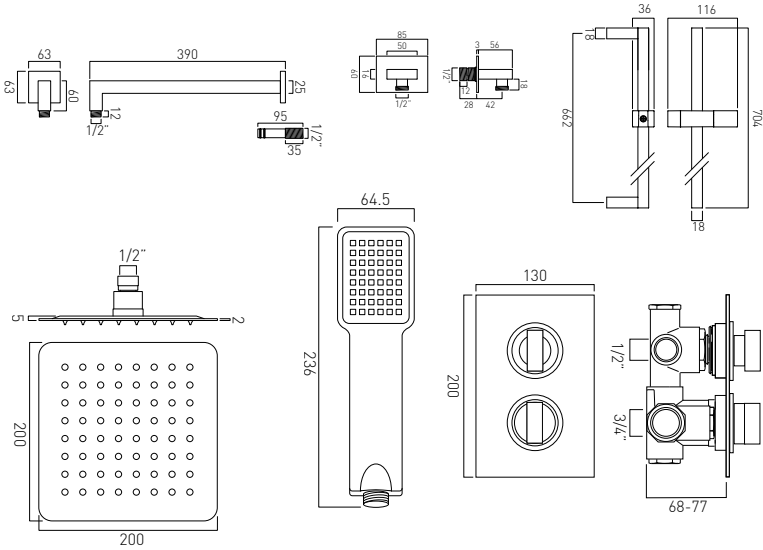

1.0 bar MP
 WG-NOTBOX/2/A-C/P €859.00
 FR-SHOWER/9-C/P €10.00 (handset)
 FR-FLEXI/5-PLA €4.00 (fixed head)

optimum valve installation depth 73mm (standard)
 optimum valve installation depth 90mm (with extension kit below)
 1x NOT-148/2/3/FLOW-EXT €21.00
 1x NOT-148C/TEMP-EXT €21.00
 (both items are required)

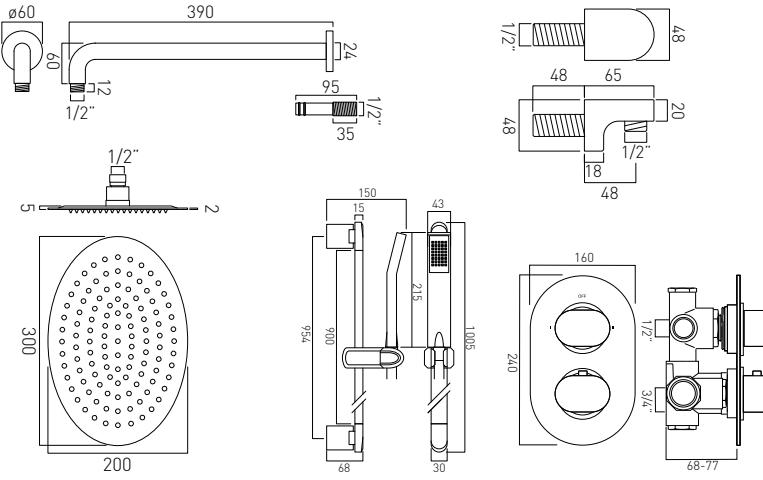

1.0 bar MP
 WG-LIFBOX/2-C/P €859.00
 FR-SHOWER/9-C/P €10.00 (handset)
 FR-FLEXI/5-PLA €4.00 (fixed head)

optimum valve installation depth 73mm (standard)
 optimum valve installation depth 90mm (with extension kit below)
 1x CEL-148/2/3/FLOW-EXT €21.00
 1x CEL-148C/TEMP-EXT €21.00
 (both items are required)

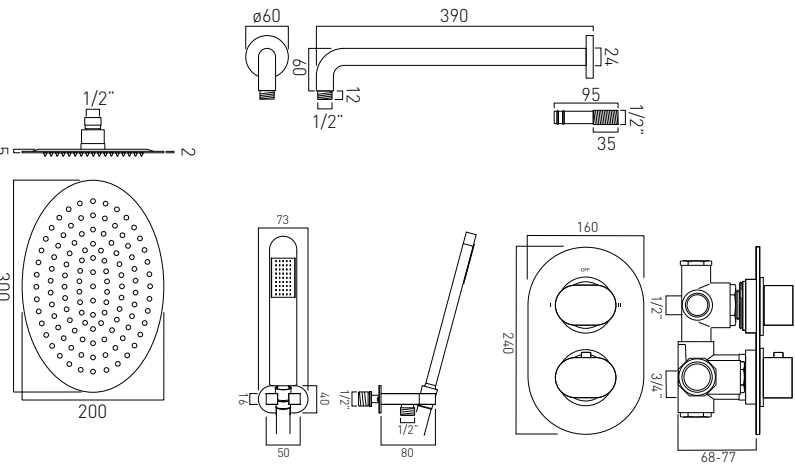

1.0 bar MP
 WG-LIFBOX/4-C/P €735.00
 FR-SHOWER/9-C/P €10.00 (handset)
 FR-FLEXI/5-PLA €4.00 (fixed head)

optimum valve installation depth 73mm (standard)
 optimum valve installation depth 90mm (with extension kit below)
 1x CEL-148/2/3/FLOW-EXT €21.00
 1x CEL-148C/TEMP-EXT €21.00
 (both items are required)



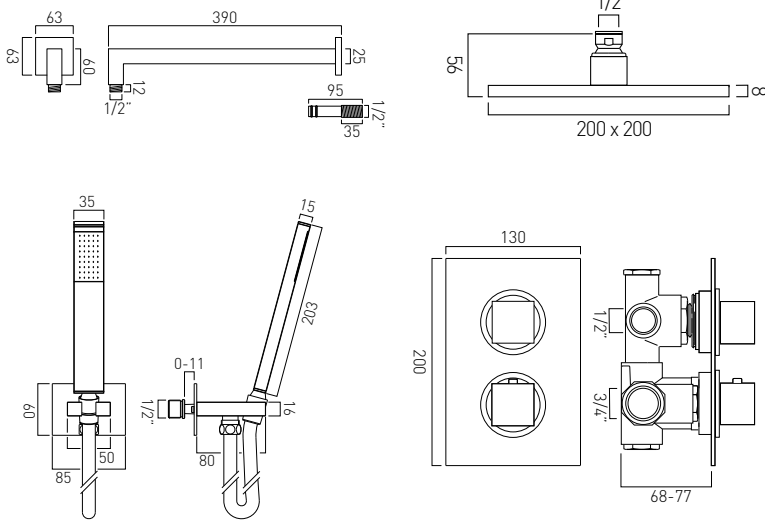

1.0 bar MP
 MIX-1721-C/P £799.00
 FR-SHOWER/9-C/P £10.00 (handset)
 FR-FLEXI/5-PLA £4.00 (fixed head)

optimum valve installation depth 73mm (standard)
 optimum valve installation depth 90mm (with extension kit below)
 1x CEL-148/2/3FLOW-EXT £21.00
 1x CEL-148C/TEMP-EXT £21.00
 (both items are required)

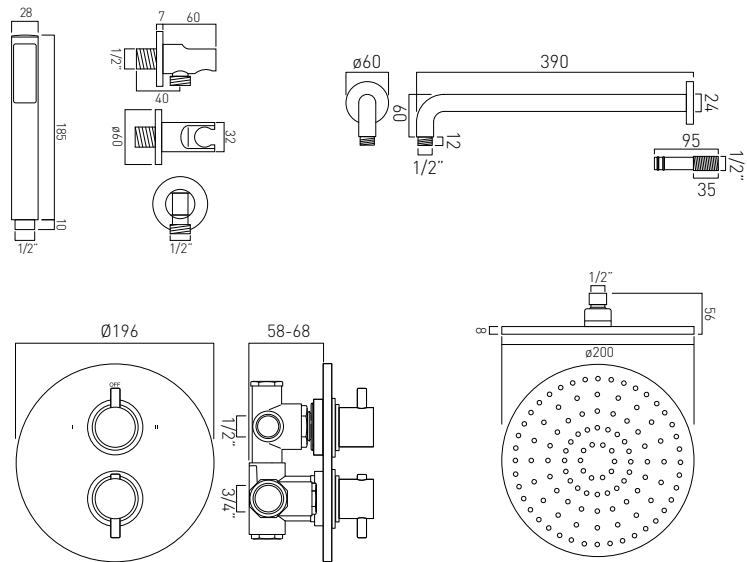

1.0 bar MP
 CEL-1721/RO-C/P £779.00
 FR-SHOWER/9-C/P £10.00 (handset)
 FR-FLEXI/5-PLA £4.00 (fixed head)

optimum valve installation depth 73mm (standard)
 optimum valve installation depth 90mm (with extension kit below)
 1x CEL-148/2/3FLOW-EXT £21.00
 1x CEL-148C/TEMP-EXT £21.00
 (both items are required)

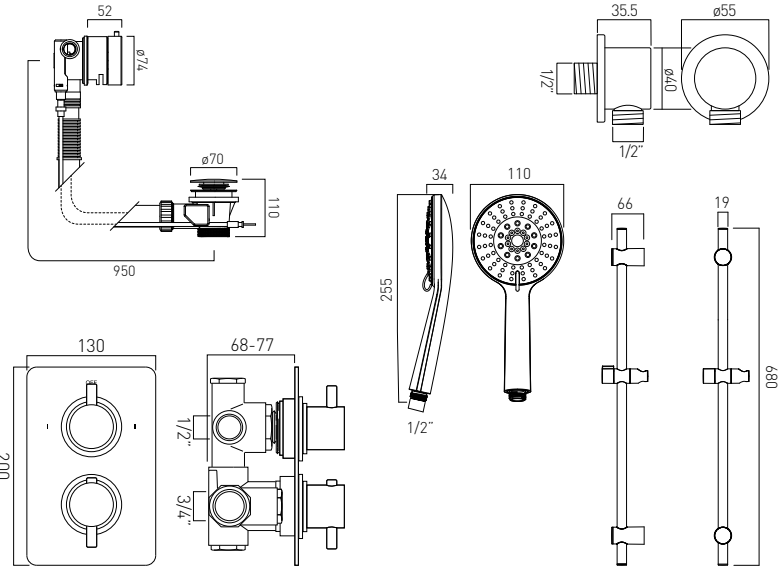

1.5 bar MP
 CEL-1723-21-C/P £879.00
 FR-SHOWER/9-C/P £10.00

optimum valve installation depth 73mm (standard)
 optimum valve installation depth 90mm (with extension kit below)
 1x CEL-148/2/3/FLOW-EXT £21.00
 1x CEL-148C/TEMP-EXT £21.00
 (both items are required)



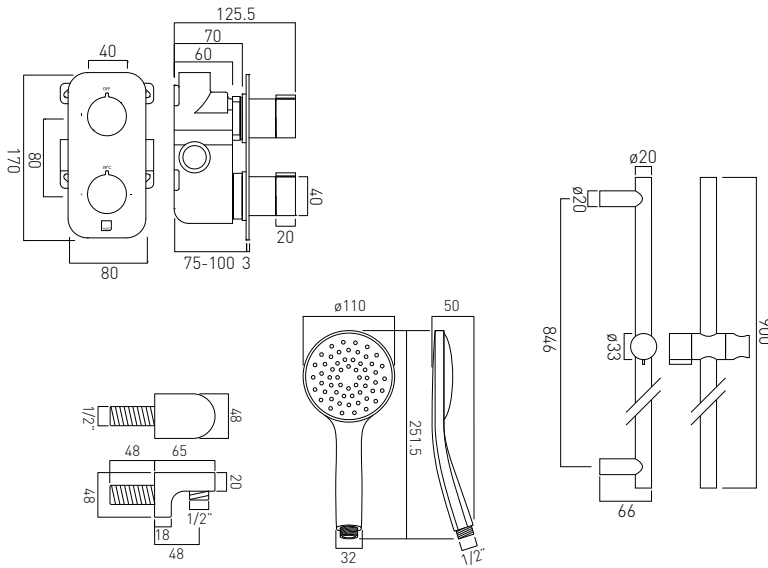

0.2 bar LP
 TAB-1710/ALT-AS-CP €633.00
 Eto FR-SHOWER/9-C/P €10.00

optimum valve installation depth 88mm

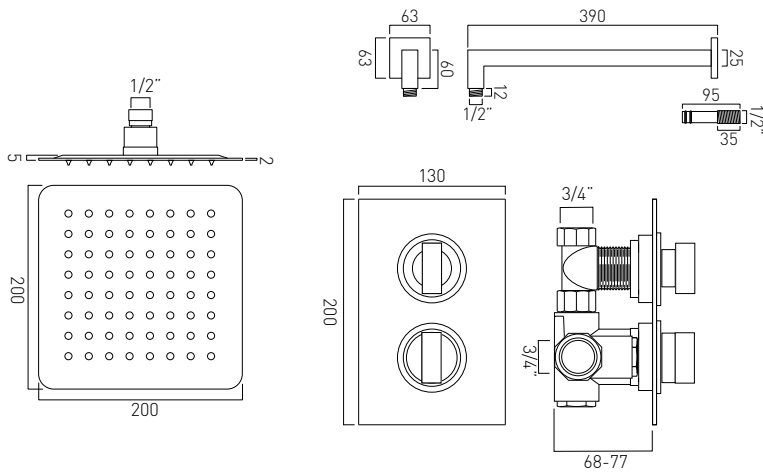

0.2 bar LP
 WG-NOTBOX/A-C/P €549.00
 Eto FR-FLEXI/5-PLA €4.00

optimum valve installation depth 73mm (standard)
 optimum valve installation depth 90mm (with extension kit below)
 1x NOT-148/2/3/FLOW-EXT €21.00
 1x NOT-148C/TEMP-EXT €21.00
 (both items are required)

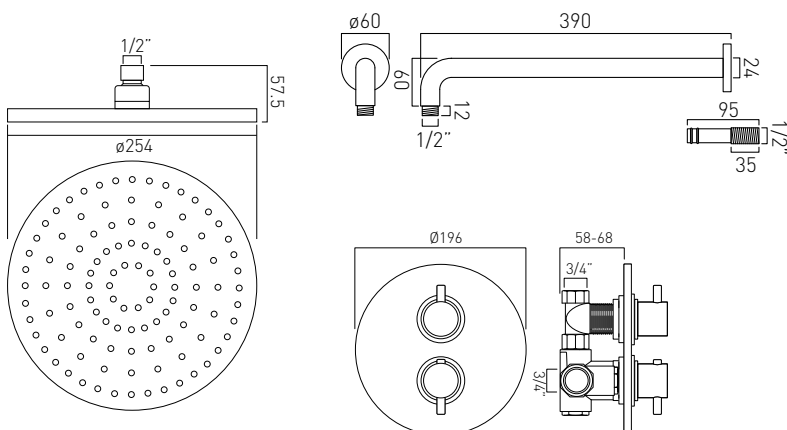

0.5 bar LP
 WG-CELBXRO/SAT-C/P €538.00
 Eto FR-SHOWER/9-C/P €10.00

optimum valve installation depth 63mm (standard)
 optimum valve installation depth 82mm (with extension kit below)
 1x CEL-148/2/3/FLOW-EXT €21.00
 1x CEL-148C/TEMP-EXT €21.00
 (both items are required)



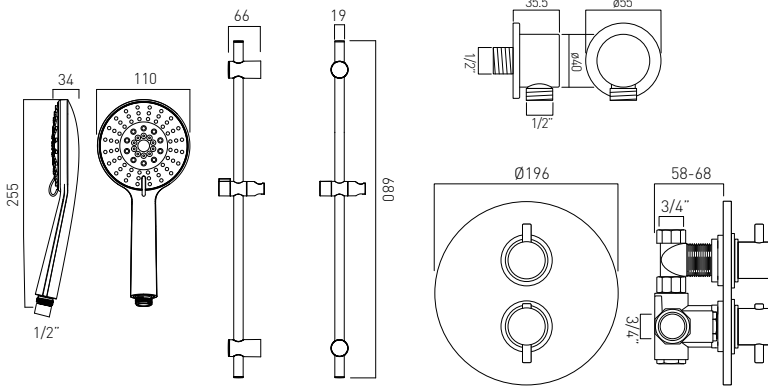

0.2 bar LP
 CEL-1710-11-C/P £582.00
 FR-SHOWER/9-C/P £10.00

optimum valve installation depth 63mm (standard)
 optimum valve installation depth 82mm (with extension kit below)
 1x CEL-148/2/3/FLOW-EXT £21.00
 1x CEL-148C/TEMP-EXT £21.00
 (both items are required)



see page 51

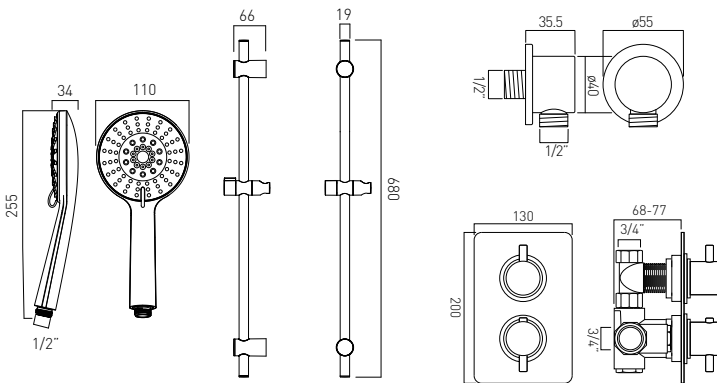

0.2 bar LP
 CEL-1710-21-C/P £582.00
 FR-SHOWER/9-C/P £10.00

optimum valve installation depth 73mm (standard)
 optimum valve installation depth 90mm (with extension kit below)
 1x CEL-148/2/3/FLOW-EXT £21.00
 1x CEL-148C/TEMP-EXT £21.00
 (both items are required)



see page 51

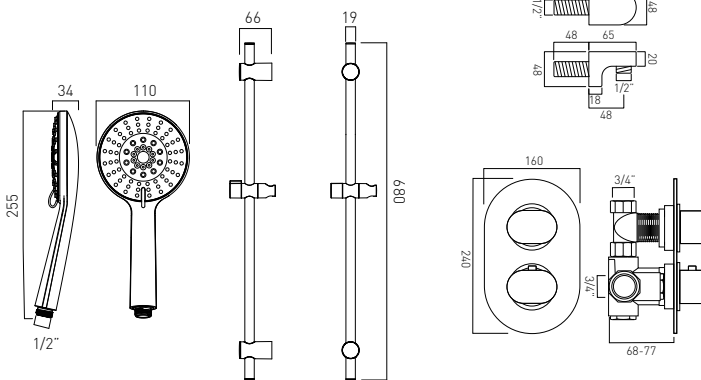

0.2 bar LP
 LIF-1710-31-C/P £582.00
 FR-SHOWER/9-C/P £10.00

optimum valve installation depth 73mm (standard)
 optimum valve installation depth 90mm (with extension kit below)
 1x CEL-148/2/3/FLOW-EXT £21.00
 1x CEL-148C/TEMP-EXT £21.00
 (both items are required)



see page 51

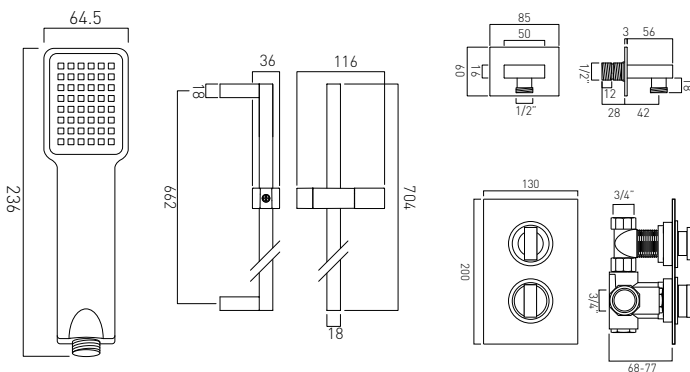

0.2 bar LP
 WG-NOTBOX/5-C/P £582.00
 FR-SHOWER/9-C/P £10.00

optimum valve installation depth 73mm (standard)
 optimum valve installation depth 90mm (with extension kit below)
 1x NOT-148/2/3/FLOW-EXT £21.00
 1x NOT-148C/TEMP-EXT £21.00
 (both items are required)



see page 51

new

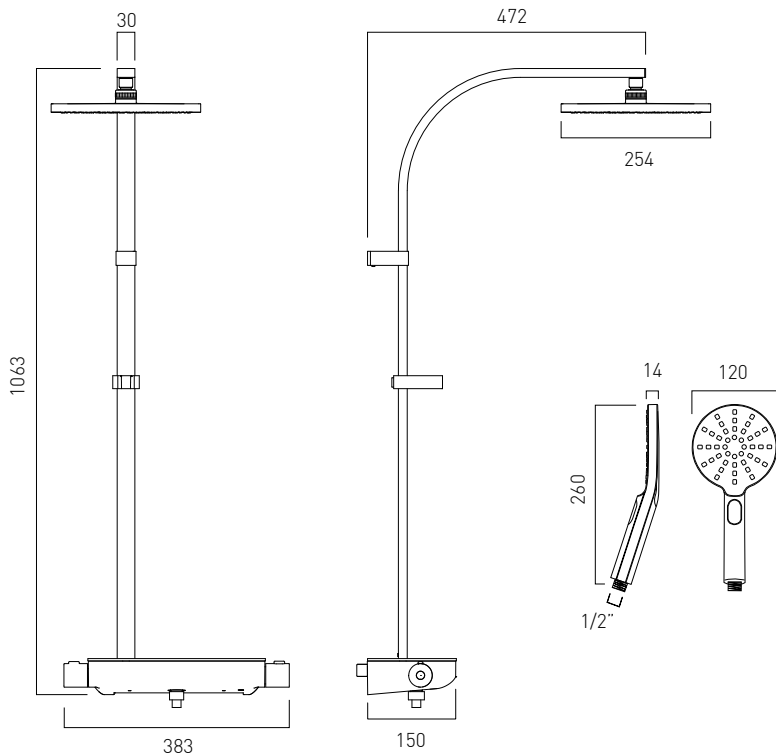

1.0 bar MP
 STRA-149/RRK-W/C £765.00
 FR-SHOWER/9-C/P £10.00 (2 are required)



new

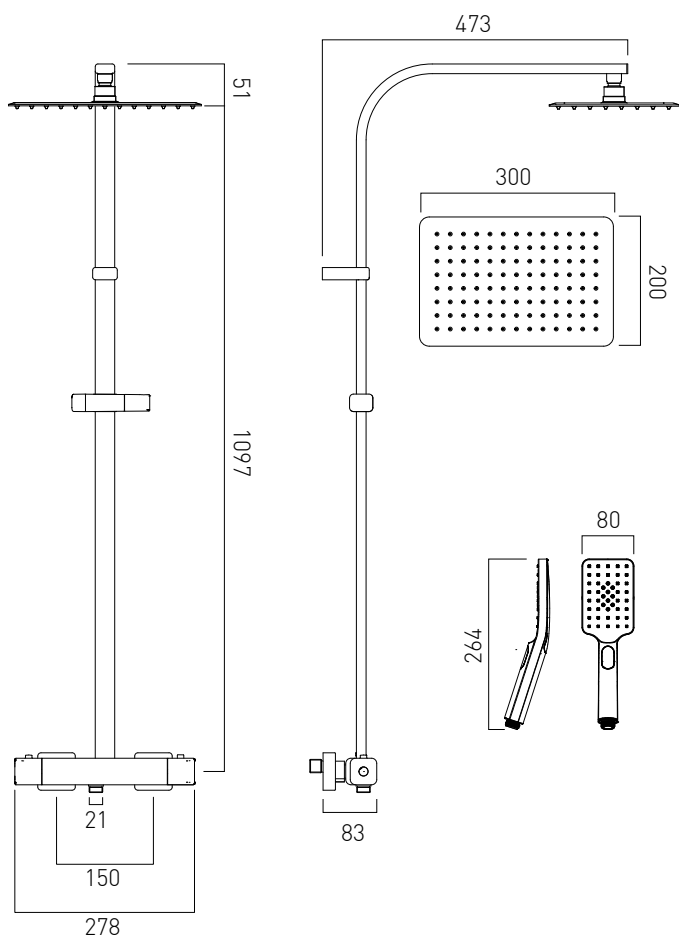

1.0 bar MP
 PHA-149/RRK-C/P £712.00
 FR-SHOWER/9-C/P £10.00 (handset)
 FR-FLEXI/5-PLA £4.00 (fixed head)



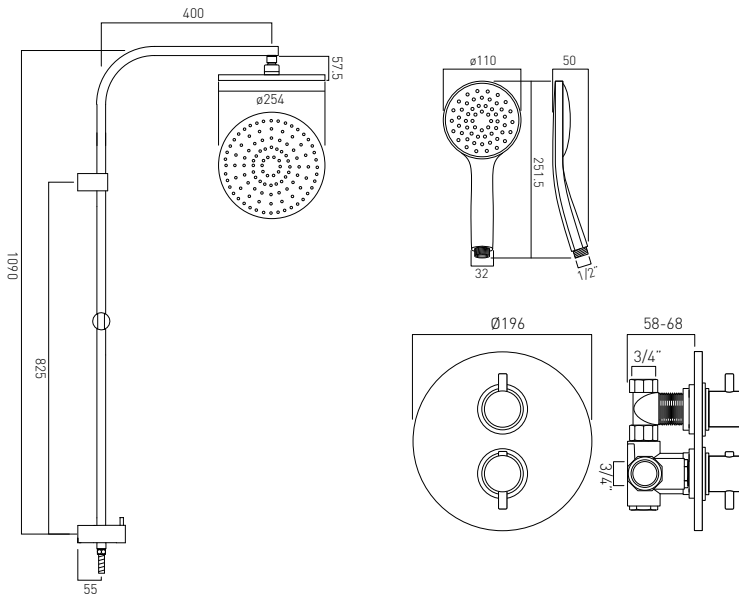

1.0 bar MP
 WG-CELBXR0/RRK-C/P £824.00
 FR-SHOWER/9-C/P £10.00 (2 are required)

optimum valve installation depth 63mm (standard)
 optimum valve installation depth 82mm (with extension kit below)
 1x CEL-148/2/3/FLOW-EXT £21.00
 1x CEL-148C/TEMP-EXT £21.00
 (both items are required)



see page 51

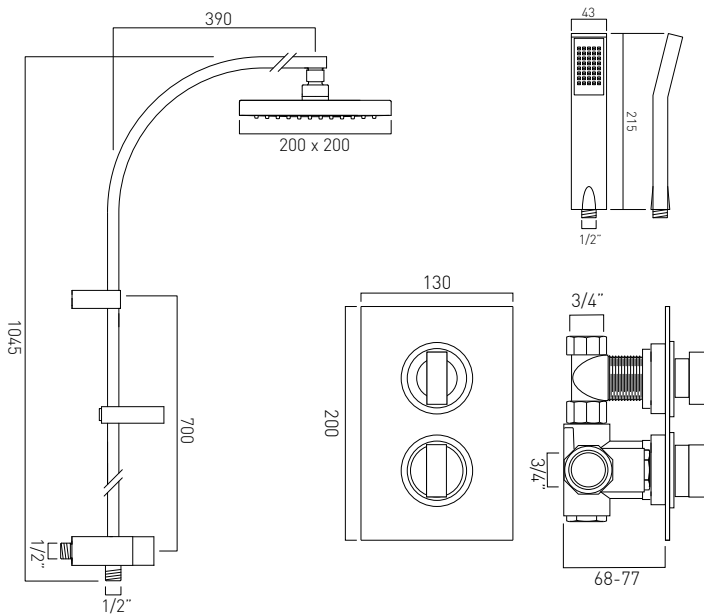

1.0 bar MP
 WG-CELBXNOT/RRK-C/P £824.00
 FR-SHOWER/9-C/P £10.00 (2 are required)

optimum valve installation depth 73mm (standard)
 optimum valve installation depth 90mm (with extension kit below)
 1x CEL-148/2/3/FLOW-EXT £21.00
 1x CEL-148C/TEMP-EXT £21.00
 (both items are required)



see page 51

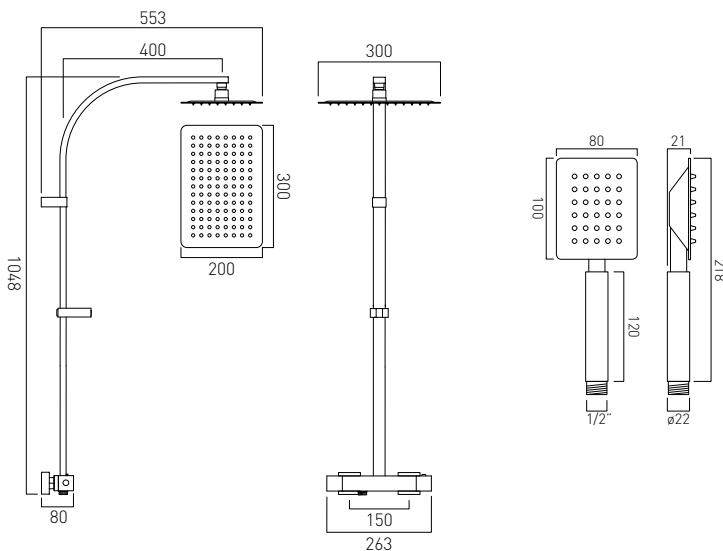

1.5 bar MP
 VEL-149/RRKSQ/AQB-CP £499.00
 FR-FLEXI/5-PLA £4.00 (2 are required)



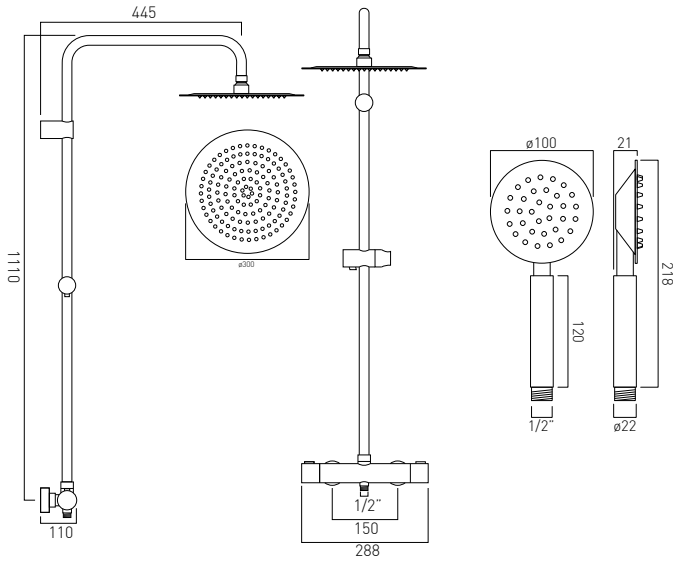

1.5 bar MP
 VEL-149/RRKRO/AQB-CP £499.00
 FR-FLEXI/5-PLA £4.00 (2 are required)

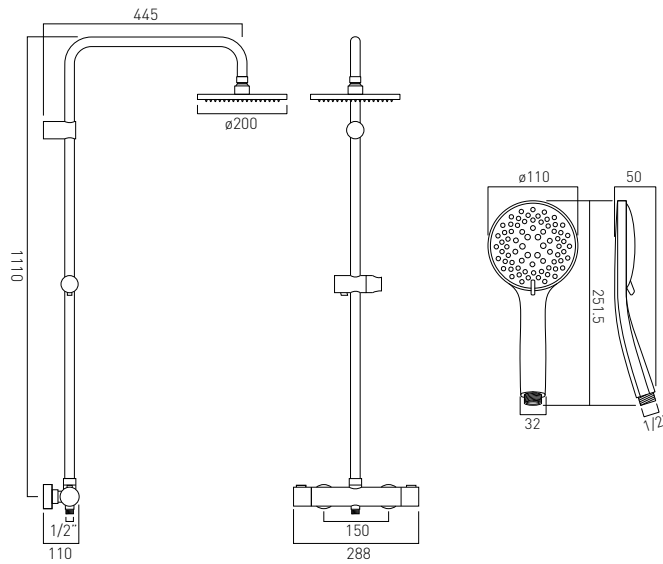

1.5 bar MP
 VEL-149/RRKRO/ATM-CP £499.00
 FR-SHOWER/9-C/P £10.00 (handset)
 FR-FLEXI/5-PLA £4.00 (fixed head)

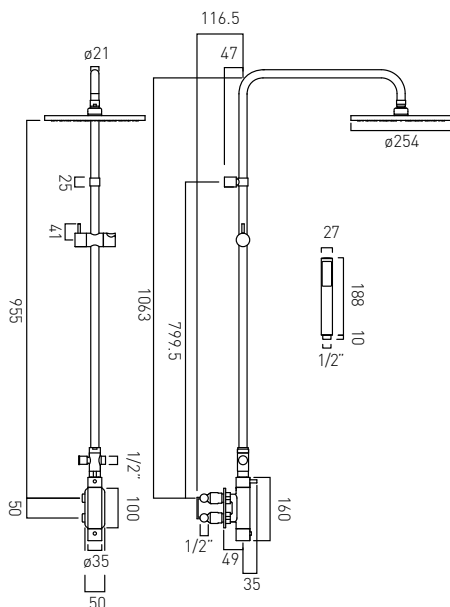

1.5 bar MP
 VER-149/RO/RRK-C/P £493.00
 FR-SHOWER/9-C/P £10.00 (2 are required)



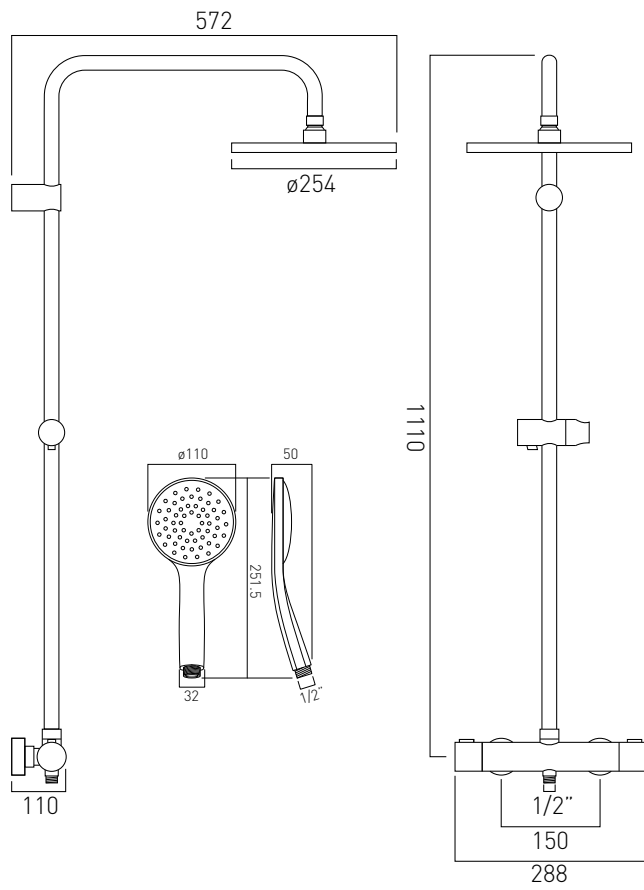

1.5 bar MP
 VEL-149RRK/DIV/ST-CP £499.00
 FR-SHOWER/9-C/P £10.00 (2 are required)
 MP HP 2 outlet air injection technology

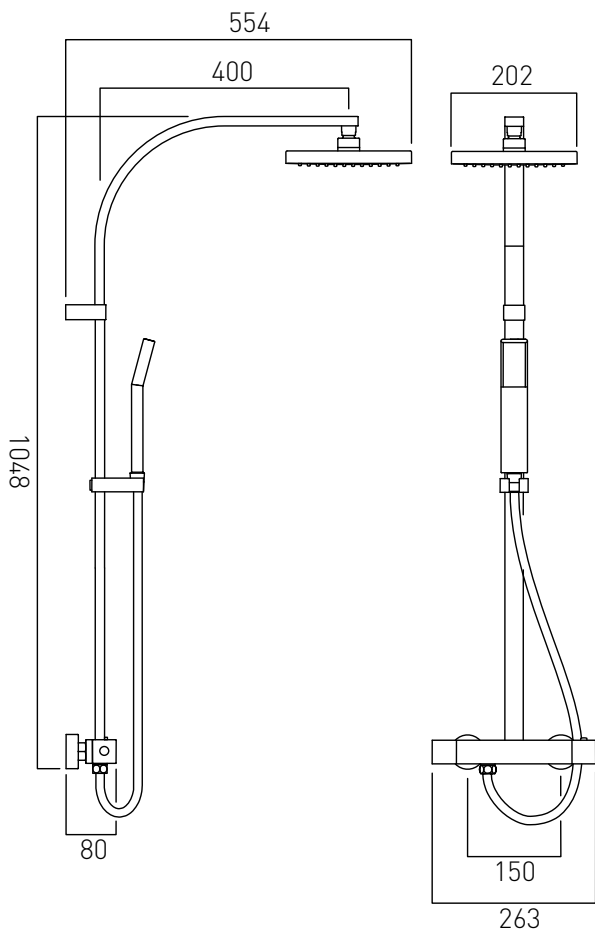

1.5 bar MP
 VEL-149/RRKSQ/DIV-CP £499.00
 FR-SHOWER/9-C/P £10.00 (2 are required)
 MP HP 2 outlet

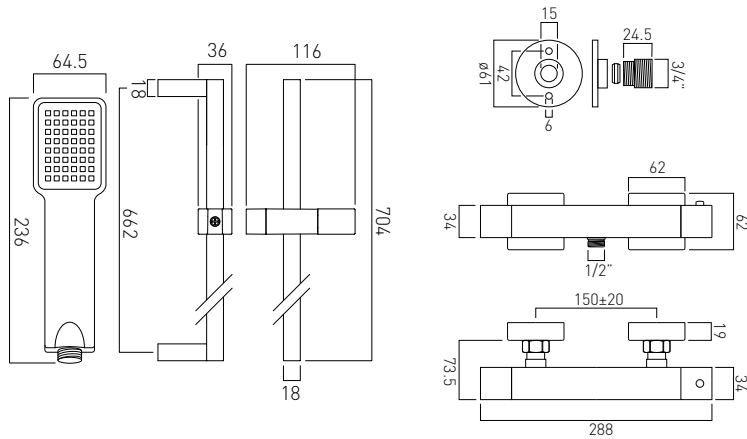

0.2 bar LP
 WG-TEBOX149/B-1/2-CP €378.00
 WG-TEBOX149-1/2-C/P €355.00 without wall mounting brackets
 FR-SHOWER/9-C/P €10.00

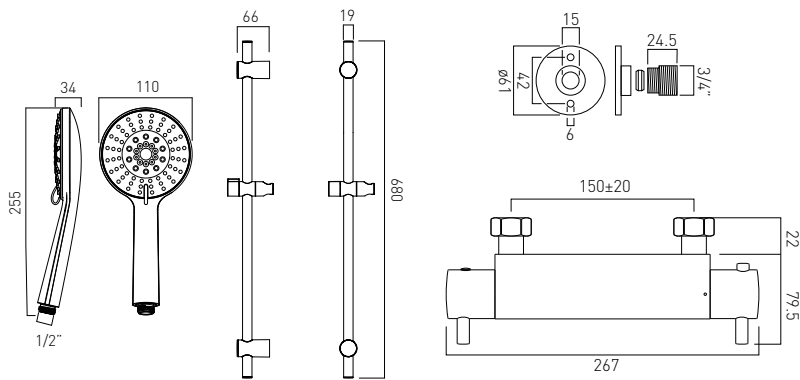

0.2 bar LP
 CEL-1701-3/4-11-C/P €362.00
 CEL-1700-3/4-11-C/P €339.00 without wall mounting brackets
 FR-SHOWER/9-C/P €10.00

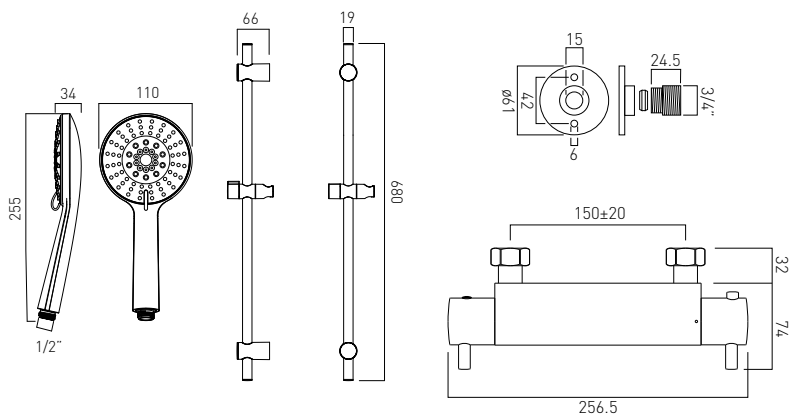

0.2 bar LP
 CEL-1701-1/2-11-C/P €339.00
 CEL-1700-1/2-11-C/P €316.00 without wall mounting brackets
 FR-SHOWER/9-C/P €10.00



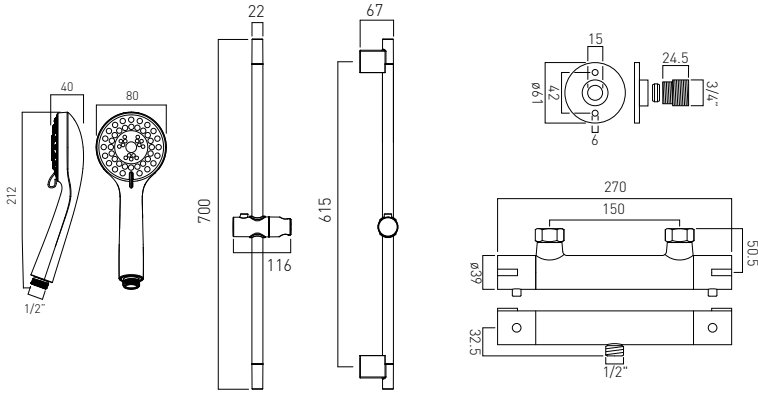

0.2 bar LP
 PRIMABOX4/B-MF-C/P €249.00
 PRIMABOX4-MF-C/P €229.00 without wall mounting brackets
 Eto FR-SHOWER/9-C/P €10.00

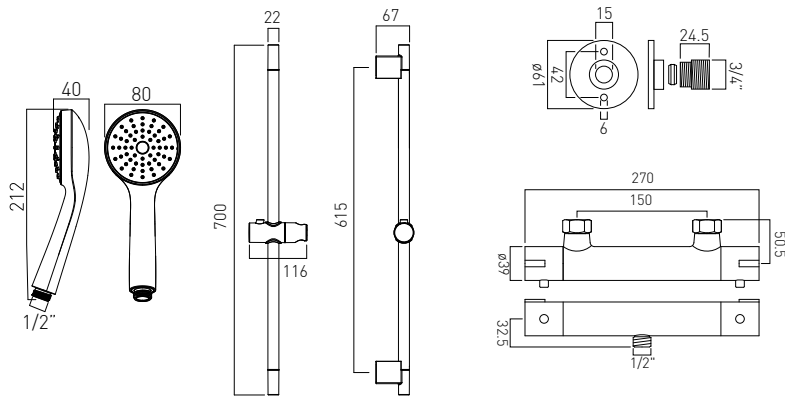

0.2 bar LP
 PRIMABOX4/B-SF-C/P €229.00
 PRIMABOX4-SF-C/P €199.00 without wall mounting brackets
 Eto FR-SHOWER/9-C/P €10.00

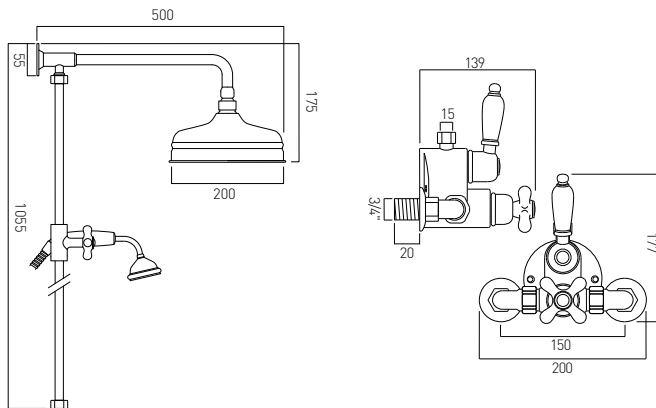

1.0 bar MP
 MAJESTIQ/RRK-C/P €1,539.00
 Eto FR-SHOWER/9-C/P €10.00 (2 are required)



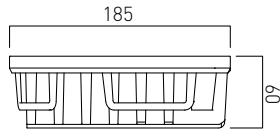
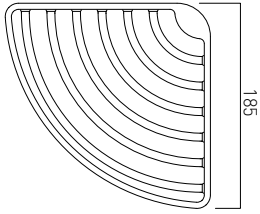

removable corner basket
wall mounted
BAS-2000-C/P €95.00

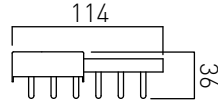
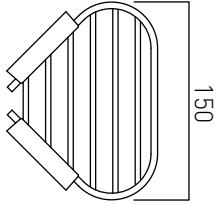

small triangular corner basket
wall mounted
BAS-2015S-C/P €36.00

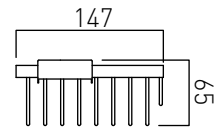
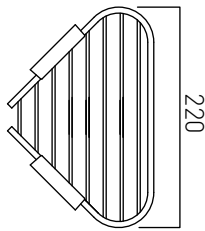

medium triangular corner basket
wall mounted
BAS-2015M-C/P €46.00

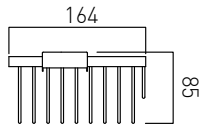
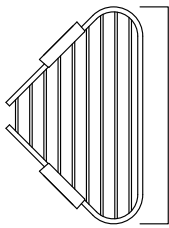

large triangular corner basket
wall mounted
BAS-2015L-C/P €98.00

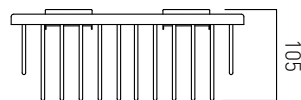
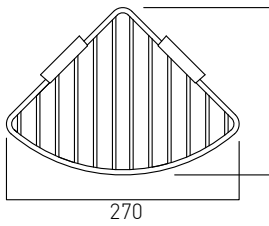

large triangular corner basket
wall mounted
BAS-2012-C/P €85.00

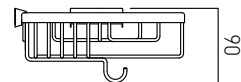
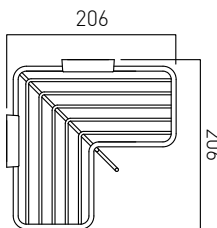

large double triangular corner basket
wall mounted
BAS-2014-C/P €119.00

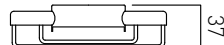
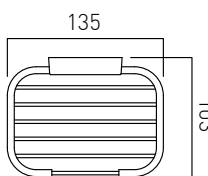

small rectangular basket
wall mounted
BAS-2001-C/P €36.00

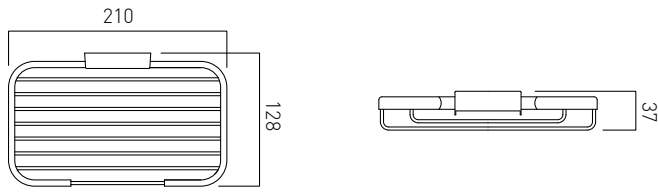

medium rectangular basket
wall mounted
BAS-2002-C/P €42.00

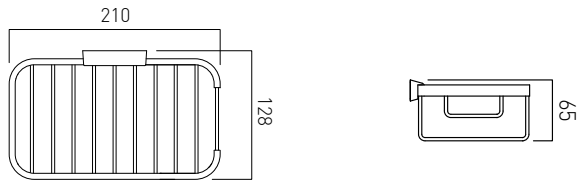

medium rectangular basket
wall mounted
BAS-2016M-C/P €59.00

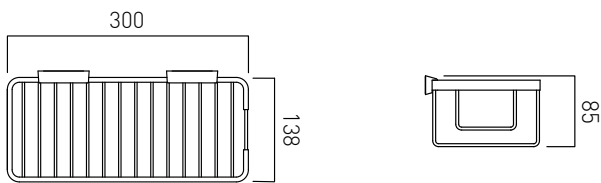

large rectangular basket
wall mounted
BAS-2016L-C/P €73.00

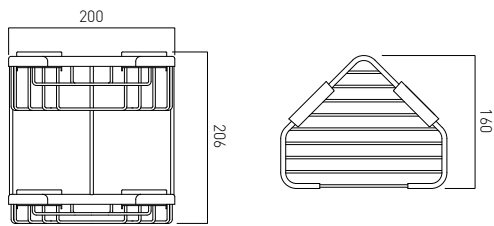

large double triangular corner basket
wall mounted
BAS-2013-C/P €98.00

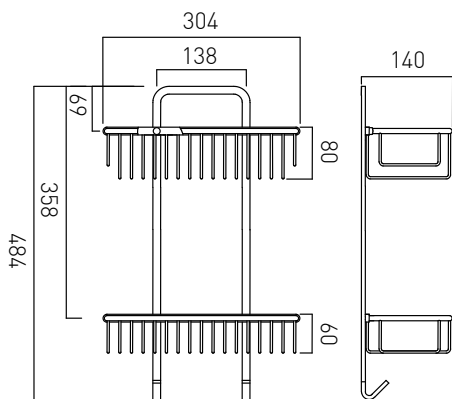

large double rectangular basket
wall mounted
BAS-2003-C/P €179.00

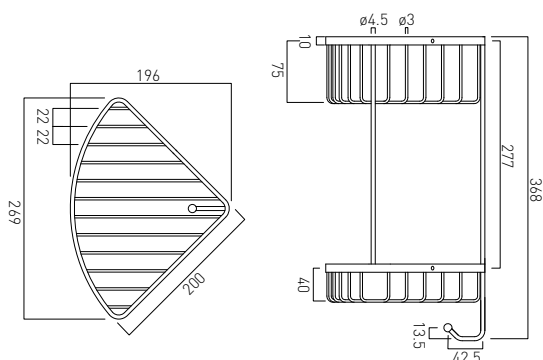

large double triangular corner basket
wall mounted
BAS-2004-C/P €127.00

returns

RETURNS PROCEDURE

Note to retailers: We do not operate a sale or return policy. However, in the event that you need to return products to us for any reason the following procedure should help to ensure that we handle your request efficiently.

Please note goods which are no longer required and that have been held by you for longer than three months from date of invoice cannot be considered for return and credit.

A Collection Request in the form of a Debit Note or VADO Collection Request Note should be faxed or emailed to our Collections Department:

1.
 - Collections Fax No: 01934 749949
 - e-mail: vado.collection@vado.com
 - Direct Telephone No: 01934 745154

We require the following details in order to process the necessary paperwork: Item stock code, finish & quantity of item(s) to be returned, the relevant Invoice Number or Delivery Note Number and the reason for return of the item(s).

2. Our Collections Department will process the paperwork and after the collection request has been authorised, we will forward by post a self-adhesive label(s) for you to confirm all details and attach to the parcel(s). You will also receive a Returned Goods Authorisation Note. The details of this note need to be checked and signed by you. This note is to be enclosed in the parcel being returned. A copy of the Returned Goods Authorisation Note for your records will also be enclosed with the label. If you have any queries whatsoever regarding the collection, please telephone our Collections Department, on receipt of label(s) 01934 745154.

3. All goods are to be suitably packaged before despatch to VADO, i.e. presentation boxes packed inside an outer box. Goods received back in anything other than re-saleable condition, may result in a request for credit being refused.
4. With the exception of faulty or damaged goods, all goods being returned will be subject to a 25% re-stocking charge with a minimum £15 charge being applicable.
5. If items are received damaged or faulty no charge is made for returning the goods to us. Please note: shortages and damages must be notified within 2 days of receipt of goods. Notification outside of the 2-day period will void any claim. If, after our inspection, a product is found to be defective due to a manufacturing fault we will issue a credit or a free of charge replacement.
6. Our collections department will liaise with your designated contact, confirming the total number of boxes packed ready for collection and a mutually convenient collection date will be arranged.

guarantee

VADO chrome products have a 12 year guarantee

VADO electric showers have a 2 year guarantee

DEFINITIONS

In these conditions 'the Company' shall mean VADO a division of Norcros Group (Holdings) Limited, 'the purchaser' shall mean the person, firm or company to whom any quotation is addressed or with whom any contract is made and 'the goods' shall mean the goods and/or services agreed to be sold by the Company to the purchaser.

1. QUOTATION AND ACCEPTANCE

- a. All quotations are given and all orders are accepted on these terms which shall apply to the exclusion of and shall override any other terms stipulated or referred to by the purchaser whether in its order or any other document, or in any negotiations or communication or course of dealing established between the Company and the purchaser;
- b. No modification or amendment of these terms or addition thereto shall be effective unless made in writing and signed by a director of the Company.

2. DESCRIPTION OF AND STATEMENTS AS TO GOODS

- a. Save where the goods are stated to be sold as complying with a recognised trade or industry standard, all descriptions, specifications, drawings and particulars of weights and dimensions submitted by the Company or otherwise contained in the Company's catalogues, brochures, price lists, quotations and publicity materials are approximate only and the Company shall not be liable for their accuracy unless they are expressly incorporated into the contract in writing;
- b. These terms represent the entire agreement between the Company and the purchaser relating to the goods and such terms supersede and the purchaser shall not place any reliance upon any statements, recommendations and advice whether oral or in writing given (whether before or after the acceptance by the Company of the purchaser's order) by the Company, its servants or agents as to any matter relating to the goods save where such statement, recommendations or advice is given in writing and signed by a director of the Company in response to a specific written request from the purchaser before or at the time of the Company's acceptance of the order.

3. PRICES

- a. Prices quoted by the Company are those in effect at the date of quotation. Unless otherwise agreed in writing, the Company reserves the right to increase prices when it accepts the purchaser's order so as to reflect one or more of the following:
 - b. any variation that may have occurred in the costs of labour, materials, suppliers overheads and transport;
 - c. any change in duty, tax, surcharge or levy of any kind whatsoever affecting the sale price of the goods;
 - d. any cost to the Company resulting from delay by the purchaser in giving to the Company information sufficient to enable it to supply the goods or provide the services or resulting from any alteration made at the request of the purchaser in the specification of the goods or in the place to which they are to be delivered or shipped; any extra cost to the Company resulting from the goods being carried at the request of the purchaser by mode of transport more expensive than the Company's normal form of transport.

4. PAYMENT

- a. Unless otherwise agreed in writing, the price for the goods will be due and payable on the last business day of the month following delivery;
- b. The Company shall be entitled to charge interest on any part of the price which is not paid in accordance with clause (a) at the rate per annum of 3% above the Base Rate of Lloyds Banking Group from time to time;
- c. Time of payment is of the essence and if the purchaser defaults in punctual payment of the price the Company shall be entitled to terminate the contract and recover the goods at the purchaser's expense without prejudice to any further rights which the Company may have;
- d. Any default in payment of an invoice or an instalment payment on an invoice on the due date shall render the entire balance outstanding on all invoices from the Company to the purchaser immediately payable in full without demand being made notwithstanding any contrary provisions as to terms of payment in any one or all invoices;
- e. If the purchaser fails to give all instructions reasonably required by the Company and all necessary document, licences, consents and authorities for forwarding the goods or is unable to accept delivery of the goods at the time when the goods are due and ready for despatch or delivery or shall otherwise cause or request delay, the purchaser shall pay to the Company all costs and expenses, including storage and insurance charges incurred or arising from such delay during which, at the Company's absolute discretion if its storage facilities permit, the goods will be stored at the purchaser's sole risk. This provision shall be in addition to and not in substitution for any other payment or damages for which the purchaser may be liable in respect of his failure to take delivery at the appropriate date;
- f. The purchaser shall not be entitled to make any deduction from the price of goods which have been delivered to the purchaser in respect of any set off or counterclaim unless both the validity and the amount thereof have been expressly admitted in writing by the Company and such admission is signed by a director of the Company;
- g. In the absence of any specific appropriation by the purchaser, the Company shall have the right to appropriate any payment made by the purchaser towards the satisfaction of any invoice outstanding from time to time as the Company shall in its absolute discretion think fit.

5. DELIVERY

- a. Any time or date stated for delivery is given and intended as an estimate only and the Company shall not be liable for any loss or damage whatsoever resulting from any delay in delivery howsoever arising;
- b. Unless otherwise stated in writing delivery shall be deemed to take place upon the occurrence of the first in time of the following, namely:
 - i. the physical delivery of the goods to the purchaser at the Company's works;
 - ii. the physical delivery of the goods to the purchaser's carrier or agent for the purpose of transmission to the purchaser or his nominee;
 - iii. the physical delivery of the goods to the purchaser's place of business or such other place as he may direct by the Company, its carrier or agent, the purchaser being responsible for unloading;
- c. Signature of the Company's delivery note by any employee, representative or agent of the purchaser shall be conclusive proof of delivery;
- d. Where the contract provides for delivery by the Company, its carrier or agent:
 - i. any claims for non-delivery must be made in writing to the Company within three days of receipt of invoice or advice note whichever is the earlier;
 - ii. any claims in respect of goods damaged in transit or shortages in delivery must be made in writing to the Company within three days of delivery; shortages in delivery shall not give rise to a right to reject the goods delivered;
- e. The Company shall be entitled to make partial deliveries or deliveries by instalments and all the provisions of these terms shall apply to such deliveries;

6. PROPERTY AND RISK

- a. Risk in the goods shall pass to the purchaser at the time at which delivery takes place in accordance with clause 5 above and the purchaser shall be solely responsible for insuring the goods thereafter;
- b. The Company shall retain ownership of and title in the goods delivered until full payment has been made in respect of all such goods. Until such time the goods shall be:
 - i. stored separately from other goods in the possession of the purchaser;
 - ii. marked or otherwise rendered identifiable as being the property of the Company;
 - iii. held by the purchaser as bailee of the Company;
 - iv. held by the purchaser free from any charge, lien or other encumbrance;
- c. Provided the Company has not requested their return and notwithstanding that payment in full has not been made for all of the goods delivered, the purchaser as principal and not as agent for the Company shall be entitled to use the goods or offer for sale and sell them in the ordinary course of his business;
- d. Where the purchaser sells the goods prior to paying for them in full:
 - i. the Company shall be legally and beneficially entitled to the proceeds of sale;
 - ii. the purchaser shall hold the proceeds of sale on trust for the Company and shall not mingle them with other monies and shall not pay them into an overdrawn bank account;

- iii. he shall deposit the proceeds of sale in a separate bank account, the location and number of which he has previously notified to the Company, and he shall not be entitled to use or deal with the proceeds of sale until payment in full for the goods has been made to the Company;
- e. The Company shall have the right at any time by its servants or agents to enter the purchaser's premises where the goods are stored, or are thought the Company to be stored, so as to:
 - i. retake possession of the goods when the Company has requested their return and the purchaser has not immediately complied with the request, such retaking or return to be without prejudice to any other rights the Company may have arising therefrom;
 - ii. inspect the storage of the Company's goods which have not been paid for in full;
 - iii. investigate and ascertain whether all these terms are being complied with;

7. GUARANTEE AND LIABILITY

- a. The Company guarantees all goods which have been manufactured by the Company against any defect of work or materials which can be proved to the Company's satisfaction to have been caused before delivery provided that:
 - i. the goods are used for their normal purpose;
 - ii. full details of any such defect are notified to the Company within thirty days of its first appearance and
 - iii. the goods in which the defect arises are returned at the purchaser's expense to the Company;
- b. The guarantee shall be for a period of twelve years from the date of delivery for all product except pumps which are 3 years for Monsoon and 1 year for Showermate and products with any other finish that is not chrome, such as gold, which are guaranteed for 3 years. The liability of the Company shall be limited at its option either to supply replacement goods, which will be supplied subject to these terms, or refunding of the goods;
- c. The Company gives no guarantee in respect of goods not manufactured by it but shall use all reasonable endeavours to procure for the purchaser or assign to the purchaser the benefit of any guarantee obtained by it from the manufacturer or supplier thereof; however the Company shall not be required to commence litigation against such manufacturer or supplier or to incur any expense in connection with any such claim by the purchaser;
- d. The above guarantee is given in lieu of and to the exclusion of all other warranties, conditions, representations and undertakings express or implied by statute or otherwise in respect of the quality or fitness for purpose of the goods or as to their condition or performance or as to any other matter except where such warranty or condition is implied by statute and by reason of a statutory provision, cannot be excluded;
- e. Save as provided herein and save in any case where death or personal injury has been caused by the Company's negligence or any case where the Company is liable for a defect in the goods pursuant to Part 1 of the Consumer Protection Act 1987 or any statutory replacement thereof, the Company shall be under no liability whatsoever to the purchaser for any loss or damage whether direct, indirect or consequential arising out of any defect in, failure of or unsuitability for any purpose of the goods or any part thereof whether the same be due to any act, omission, breach of contract, negligence or wilful default in design, workmanship or materials or any other cause.

8. INDEMNITY AS TO INDUSTRIAL PROPERTY RIGHTS

- a. The purchaser shall indemnify the Company against all loss, damages, costs and expenses suffered or incurred by the Company or to which the Company may become liable as a result of any work carried out in accordance with the purchaser's specification(s) which involves infringement or alleged infringement of a patent, registered design or other industrial property right;
- b. If the purchaser uses or sells the goods in such a manner as to infringe any such rights the company shall not be responsible for such infringement and the purchaser agrees to indemnify the Company from and against all liability arising therefrom.

9. TERMINATION

The Company shall have the right forthwith to cancel the purchaser's order if any of the following events occur and subject to enforcement of the Company's rights to recover the goods and to receive payment of the price or damages, the contract shall be deemed to have terminated:

- a. the purchaser commits any breach of its obligations to the Company;
- b. any distress or execution is levied upon any property of the purchaser;
- c. the purchaser makes or offers to make any arrangement or composition with creditors or commits any act of bankruptcy or insolvency;
- d. any resolution is passed or petition presented to wind up the purchaser;
- e. a receiver or administrator is appointed or any chargee takes possession of all or any part of the undertaking or assets of the purchaser;
- f. the purchaser stops payment or ceases or threatens to cease to carry on its business or to pay its debts as and when they fall due;
- g. any remittance for payment of the whole or any part of the purchase price of the goods is dishonoured by the purchaser's bankers.

10. ASSIGNMENT

The purchaser shall not assign or transfer or purport to assign or transfer any contract to which these terms apply to any other person without the Company's prior written consent. The Company reserves the right to subcontract the performance of the contract or any part of it.

11. FORCE MAJEURE

If the Company is prevented or delayed (directly or indirectly) from making delivery of the goods or any part thereof or from otherwise performing the contract or any part thereof by reason of war, embargo, riot, strike, lock-out, trade dispute, fire, breakdown of plant or machinery, inclement weather, interruption of transport, Government action, delay in delivery to the Company of any goods or materials, or by any cause whatsoever (whether or not of a like nature to the foregoing) outside its control, it shall be under no liability whatsoever to the purchaser and shall be entitled at its option either to cancel the contract or without any liability to extend the time or times for delivery by a period equivalent to that during which such delivery has been prevented.

12. PROPER LAW

The contract and these terms shall be governed by English law and the purchaser shall submit to the sole jurisdiction of the English Courts.

12 year guarantee

showering packages

and electric showers
january 2017

other available catalogues



trade guide

An A5 catalogue ideal for those in the trade, a concise selection of VADO's popular product offering.



consumer catalogue

VADO's tap, showering and accessory collection, the perfect catalogue to give to consumers visiting bathroom showrooms.



accessories

A comprehensive catalogue dedicated entirely to VADO accessories.



specifications manual

An essential showroom reference tool, which includes technical drawings, pressures and other fundamental technical information for all VADO products.



VADO
Wedmore Road Cheddar Somerset England BS27 3EB
tel 01934 744466
fax 01934 744345
www.vado.com
sales@vado.com

due to our policy of continual improvement, VADO reserve the right to change product specification.
the colours indicated are an approximation of the actual finishes on VADO products. e&oe.
© 2016 VADO LIT-VADO/SHWR-JAN17

